

User Manual



Tuncmatik Mini DC Charger 30-60kW Electric Vehicle Charger User Manual

Table of Contents

| | |
|-------------------------------------|----|
| 1. Safety Instructions | 1 |
| 2. Technical Specifications..... | 3 |
| 3. Introduction | 5 |
| 3.1. Product Overview..... | 5 |
| 4. Packaging | 6 |
| 5. Installation..... | 7 |
| 5.1. Pre-Installation | 7 |
| 5.2. Cable Reach | 8 |
| 5.3. Construct Foundation | 8 |
| 5.4. Dimensioned Drawing | 10 |
| 5.5. Space Requirement..... | 11 |
| 5.6. Installation Steps | 12 |
| 6. Charging Process..... | 14 |
| 6.1. Charging Process | 14 |
| 6.2. Charging Page Description..... | 18 |
| 6.3. LED Operation | 19 |
| 6.4. Precautions | 19 |
| 6.5. EPO Operation | 20 |
| 7. Routine Maintenance | 21 |
| 8. Trouble Shooting | 22 |

1. Safety Instructions

Read and follow the instructions and warnings in this Manual before attempting to install this product. Keep this Manual for future reference.

Please follow the below safety precautions to prevent bodily injuries and property damages.



Warning: When the product is running, it should pay attention to ventilation, heat dissipation and keep the environment clean. Avoid installation in places with frequent occurrence of storm, rainstorm, lightning and other severe weather.



Warning: During installation, if any abnormal phenomena such as cracking, loose case lock, water leakage are showing up, all operations shall be stopped immediately and professionals shall be informed in time to deal with them.



Warning: Do not put inflammable, explosive or combustible materials, chemicals, combustible steam and other dangerous goods near the charge pile.



Warning: Please keep the charging plugs clean and dry. If there is any dirt, please wipe it with a cleaning cadre. It is strictly prohibited to touch the charging core with hands when it is powered.



Warning: It is strictly prohibited to use the charge pile when the charge plugs or charging cable is defective, cracked, worn, and the charge plugs line is exposed. If any, please contact the staff in time.



Warning: In case of rain and thunder, please use electricity carefully. It is better to stop charging.



Warning: Do not attempt to disassemble, repair or modify the charging station. For repairs or modifications, please contact the staff. Improper operation may result in damage, water leakage, electricity leakage, etc.



Warning: It is forbidden to insert and unplug the plug during the charging process to ensure the safety of life and the vehicle during the charging process.



Warning: It is strictly prohibited to continue to use this product for charging in case of failure.



Warning: If any leakage or insulation failure occurs during the operation of the product, please press the emergency power off button immediately.



Warning: Obvious maintenance marks shall be set up. Isolation and protection measures shall be added to live parts that may be near by operators to avoid contact.

CAUTIONS



CAUTION: Wrong installation and testing of the charger will cause potential damage to the vehicle battery, assembly, and the charger itself.



CAUTION: Do not operate the charger in temperatures outside its operating range of -35°C to +55°C.

NOTE:

Electrical equipment should only be installed, operated, serviced, and maintained by qualified personnel. No responsibility is assumed by our company for any consequences arising out of the use of this material.

A qualified person is one who has skills and knowledge related to the construction, installation, and operation of electrical equipment and has received safety training to recognize and avoid the hazards involved.

If the machine line drawing in the manual is different from the actual product, do not worry, because the reference picture is the same as the installation method of the actual product

2. Technical Specifications

| MODEL | | 5430G | 5460G |
|--------------------------------|----------------|---|---|
| Charging Type | | DC fast charging | |
| Outlet Options | | C: CCS2 cable , A: CCS1 cable , J: CHAdeMO cable , G: GBT cable | |
| AC Input Power | | 48 A, 33 kVA | 93 A, 64 kVA |
| Input Voltage Range | | 380/400/415 VAC +/- 10% | |
| Input Frequency | | 50 Hz or 60 Hz | |
| DC Output Power Rating | | 30 kW | 60 kW |
| DC Output Voltage | | 200-1000 Vdc (Constant power from 300-1000Vdc) | |
| Number of EV Served | | Up to 2 (JC, JA models) Up to 1 (C, A,J, G models) | Up to 2 (CC, AA, JC, JJ ,GG models) Up to 1 (C, A, G models) |
| Cable Length | | 5.0 m, Optional: 6.0 m / 7.0 m | |
| Maximum Current | CCS Cables | 80A | 150A |
| | CHAdeMO Cables | 60A | 125A |
| | GBT Cables | 60A | 150A |
| Electro-Magnetic Compatibility | | Class A (optional Class B) according to EN 61000-6-3:2007 | |
| Distribution Systems | | TN-S, TN-C, TN-C-S, TT (required external RCD) | |
| Connector Type | | 3P + N + PE | |
| Protection | | Overcurrent, overvoltage, undervoltage, integrated surge protection, ground fault including DC leakage protection | |
| Overvoltage Category | | Type II | |
| Power Factor (Full Load) | | ≥ 0.98 | ≥ 0.99 |
| THDi | | ≤ 5% | |
| Efficiency | | ≥ 93% (peak) | |
| Standby Power | | < 35 W | |
| Short Circuit Current | | 10 kA | |
| Pre-charge Current | | < 1 A | |
| Inrush Current | | < 55 A | < 100 A |
| Leakage Current | | 0.8 mA | |
| Energy Metering | | Standard: Meter for DC outlet, Optional: AC inlet | |
| Cellular Communication | | GSM, 4G, LTE | |

| USER INTERFACE | | |
|--------------------------------|--|-----|
| Connectivity | Internet access via 4G/3G/Ethernet (RJ45) | |
| User Authentication | RFID, QR code | |
| User Interface | 7" LCD high-contrast touchscreen | |
| Communication Protocols | Proprietary and OCPP 1.6J | |
| RFID Reader | ISO/IEC 14443 A/B Mifare RFID reader | |
| Emergency Button | Yes | |
| CONFIGURATION | | |
| Software Upgrade | Over-the-air (OTA) | |
| Language System | English, French, Spanish, Turkish, Russian | |
| GENERAL CHARACTERISTICS | | |
| Protection Rating | IP54 and IK10 (cabinet) / IK8 (touchscreen) | |
| Housing Material | SGCC, Optional: SUS430 | |
| Operating Altitude | Up to 2000 m | |
| Operating Temperature | -35 °C to +55 °C | |
| Storage Temperature | -40 °C to +70 °C | |
| Humidity | < 95%, non-condensing | |
| Mounting | Free-standing cabinet | |
| Dimensions (D x W x H) mm | 218 x 660 x 1250 | |
| Net Weight (kgs) | 80 | 100 |
| COMPLIANCE STANDARDS | | |
| Codes and Standards | IEC 61851-1 ed 3, IEC 61851-21-2 ed 1, IEC 61851-23 ed 1, IEC 61851-24 ed 1, IEC 62196-2, IEC 62196-3, IEC 61000, GBT18487, GBT20234 | |
| Communication to the EV | DIN 70121, ISO/IEC 15118 ed 1, CHAdeMO 1.2, GBT27930, GBT 34657 | |

* Product specifications are subject to change without further notice

3. Introduction

The DC EV charger comes with two charging plug. The maximum output power of 60kw, and the efficiency is not less than 93%. For ease of operation, the electric car charger is equipped with a 7-inch industrial touch screen, a standard Ethernet connection, and an embedded RFID reader with WI-FI features to communicate with LAN routers, vehicles, and action devices, and other chargers(Wi-Fi communication is optional).

3.1. Product Overview



- | | |
|---------------------|-------------------|
| 1. Filter device | 4. LED pilot lamp |
| 2. RFID card reader | 5. EPO button |
| 3. Nozzle | 6. Touch screen |

4. Packaging

The charger is delivered in a carton packaging. The following figure shows the packaging for the charger.

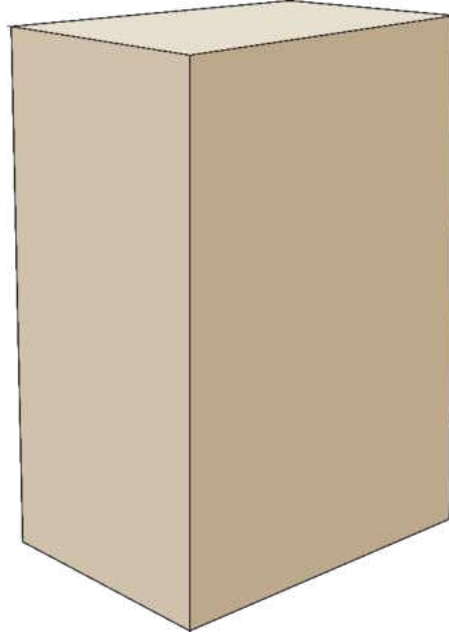

NOTE: The charger must be stored in its original packaging in a dry environment between $-40\text{ }^{\circ}\text{C}$ to $+70\text{ }^{\circ}\text{C}$.

It is recommended to ship the charger to its final destination in its original packaging and unpack it there.

5. Installation

5.1. Pre-Installation

| | |
|---|--|
|  | <ul style="list-style-type: none">● Danger to life due to improper installation!● Ignoring environmental conditions when handling electricity can lead to hazardous situations. |
|---|--|

Before performing any installation activities, carefully read each item listed in this chapter that is critical to the installation process.

[Location Selection]

Consider before choosing where to install:

- Meets all criteria regarding charger placement and location.
- Accessible Design Standards.
- Make sure the installation location complies with cellular signal strength standards.

[Local Conditions]

- Area is dry and well ventilated.
- The area is not exposed to dust, high temperatures, explosive gases, flammable materials or corrosive fumes.
- Wiring and conduit needed to connect the charger to the board.
- The location of the charging port when the vehicle is parked.
- Space clearance requires minimum dimensions for airflow and service channels.

5.2. Cable Reach

In the default configuration, the Charging station comes with a cable length of 500cm. Figure 5.1 below shows the Charging station's operating radius (5m).

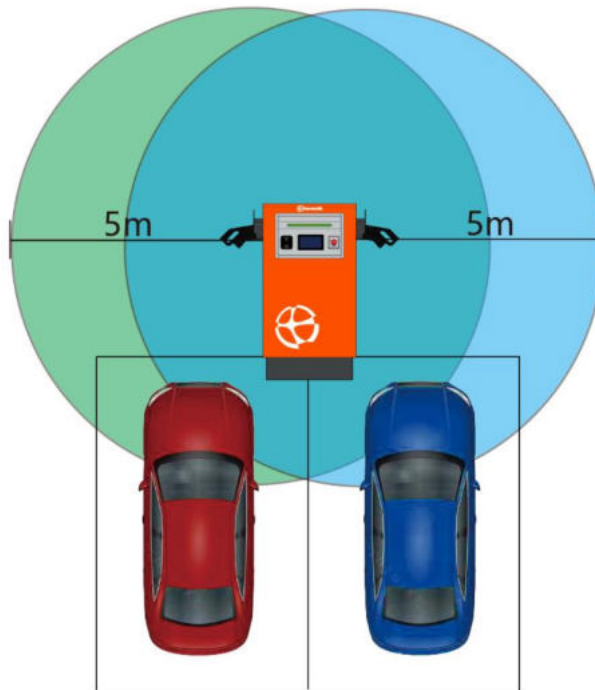

Figure 5.1

5.3. Construct Foundation

- The charging station can be built on a concrete foundation, the flat surface of foundation should not be less than the dimension of 700 mm * 700 mm.
- When preparing the foundation base and cabling pay regard to positions of cable through holes and expansion bolts, which was dimensioned in Figure 5.2.

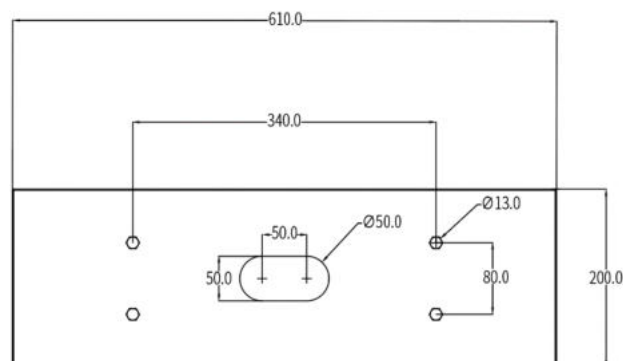

Figure 5.2

The height of the foundation is determined by the topography and natural environment of the site. Depending on rainfall and drainage a height between 15 cm and 30 cm above the ground is recommended. Because of frost-proof the foundation has to be about 80 cm deep under the ground.

NOTE:

- The unit must be mounted on solid and flat stone slabs.
- Different types of stone slabs require the use of expansion bolts, or choose suitable screw installation, in some conditions require drilling.
- The laying of power cables shall be in accordance with relPRO DC CHARGERnt national and industrial standards, specifications.
- Cable selection specification shall be selected according to the number of equipment and the type, power, voltage and current level of the equipment installed.
- When cables are laid, they are strictly forbidden to be exposed.
- When the cable is buried directly, the buried depth should not be less than 0.8m in order to prevent freezing.
- The selection of power cable specifications should be selected according to the installation environment and fire requirements.

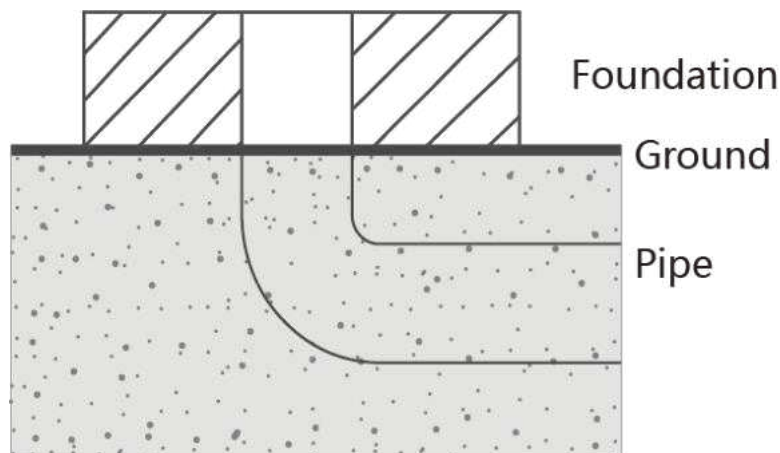
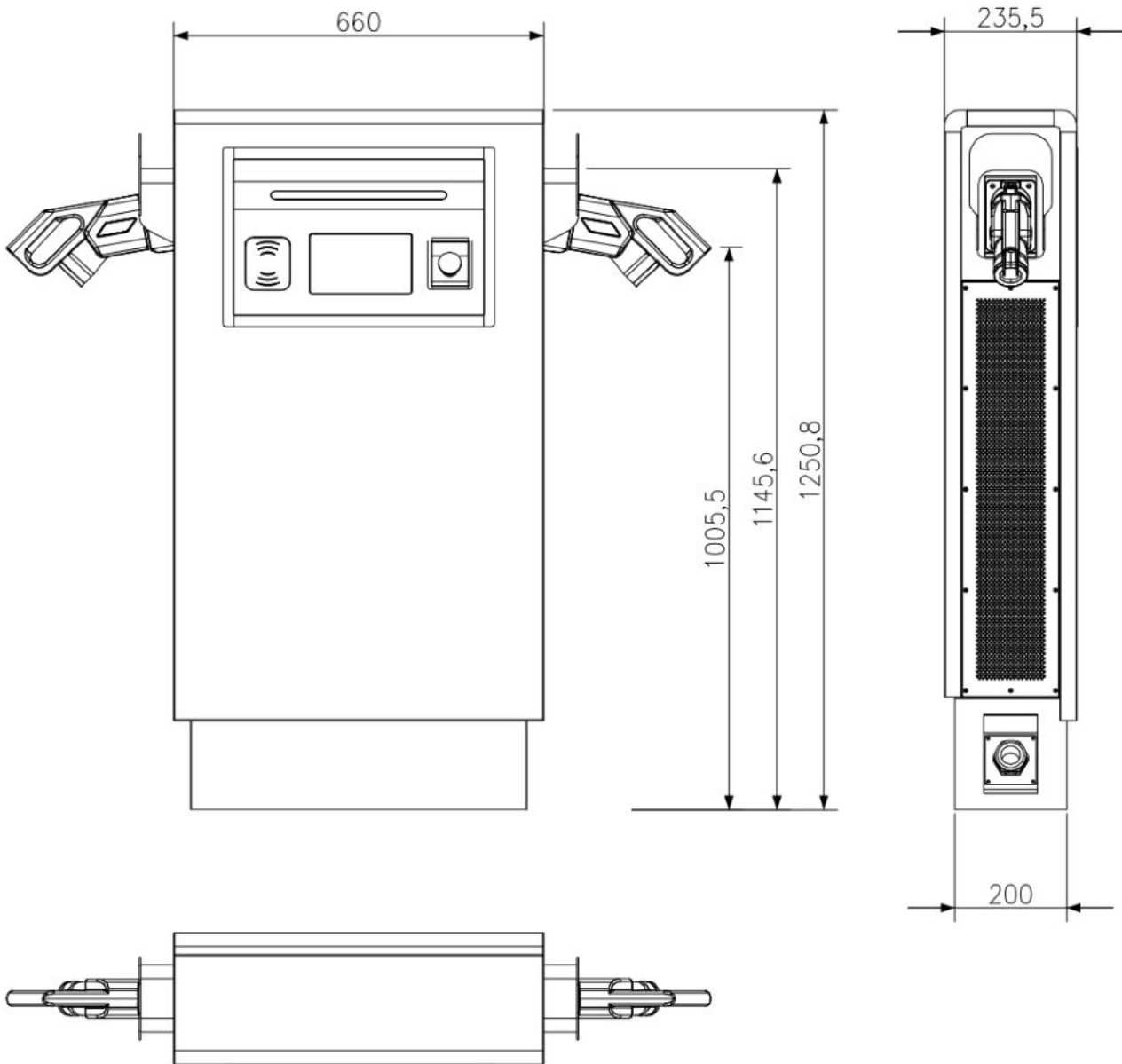

Figure 5.3

5.4. Dimensioned Drawing



5.5. Space Requirement

When installing the charger, make sure to keep a minimum distance from objects that may be around the charger to allow for adequate airflow, and secondly, to leave room for possible repair or operations.

The following diagram shows the recommended minimum distances during on-site installation:

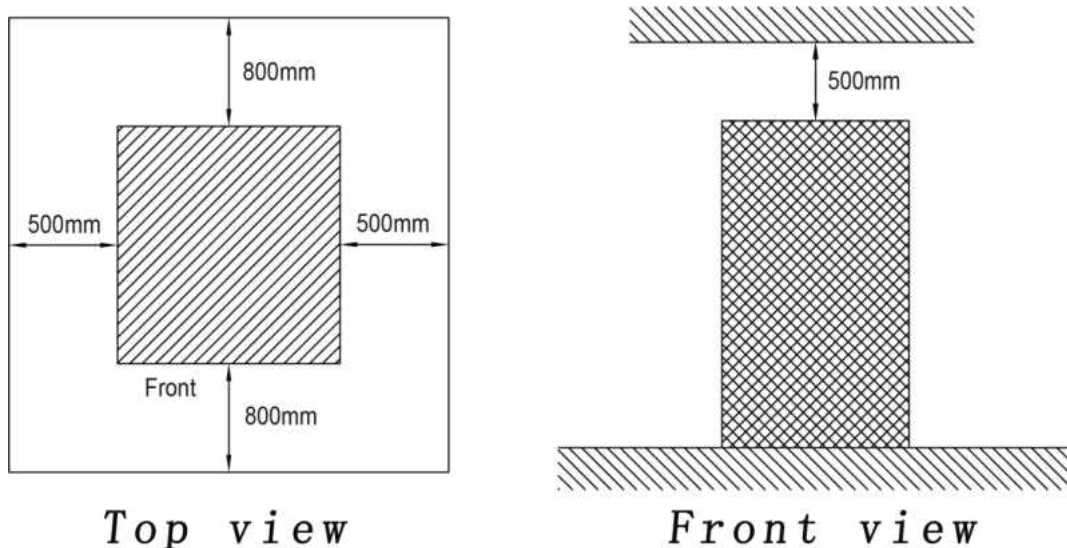

Figure 5.4

NOTE: Clearance dimensions are published for airflow and service access only. Consult your local safety regulations and standards for other requirements in your local area.

5.6. Installation Steps

Step 1. Remove the bottom plate

1. Remove the screws on the bottom plate
2. Lift the plate upward until 90°
3. Remove the plate down

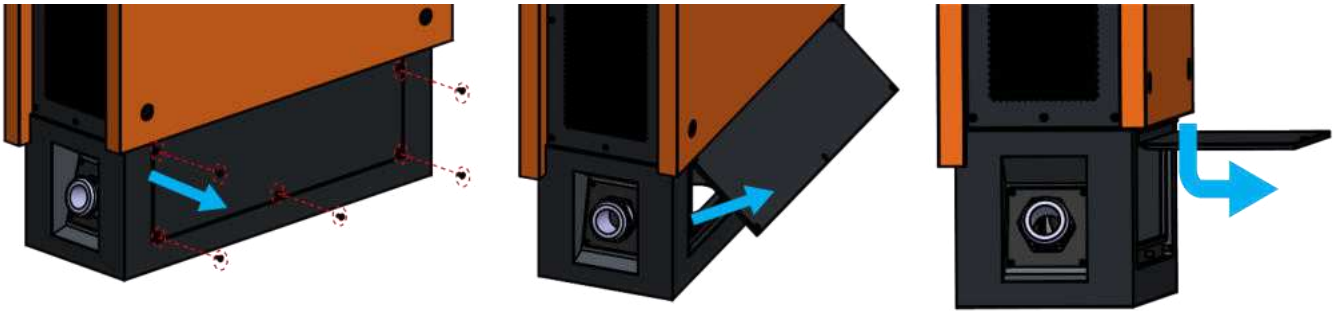

Step 2 : Main case of the charger pedestal installation

1. Use the mounting plate and leveling tool to mark the mounting position and secure the bolt stud.
2. Place the charger pedestal main case on the stone slab, and fix it with nuts.

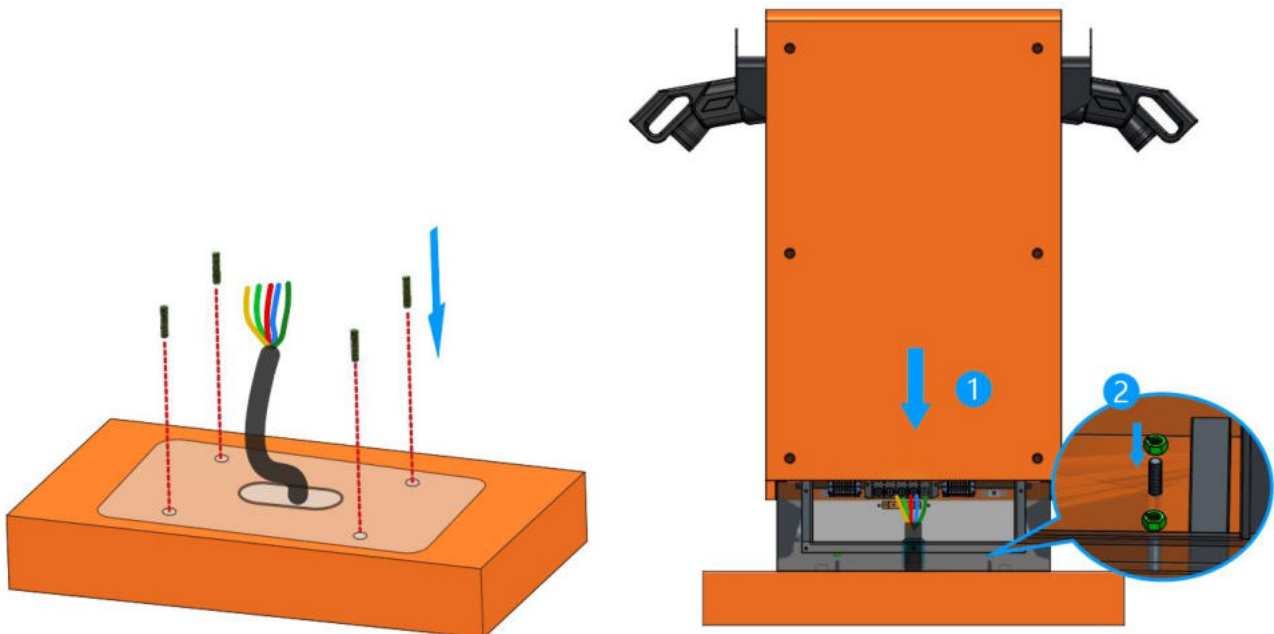

Step 3. Wire installation

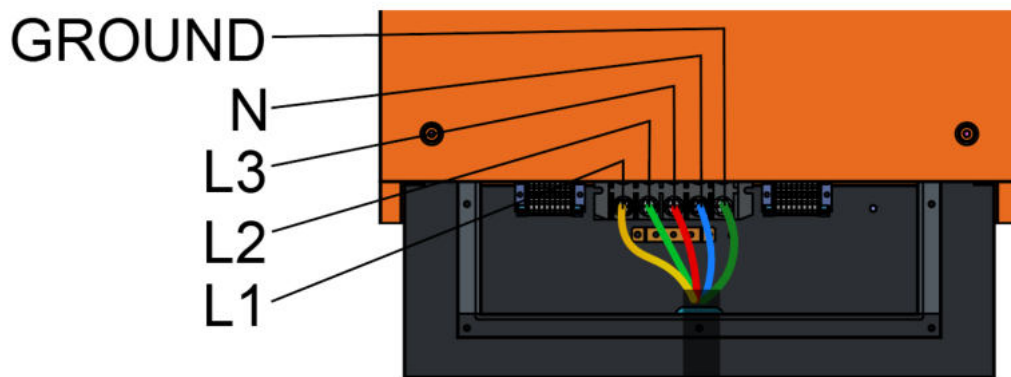

Step4. The bottom plate installation

1. Lift the board vertically so that it snaps into the internal slot
2. Lower the board to its original position
3. Fix the plate with five screws

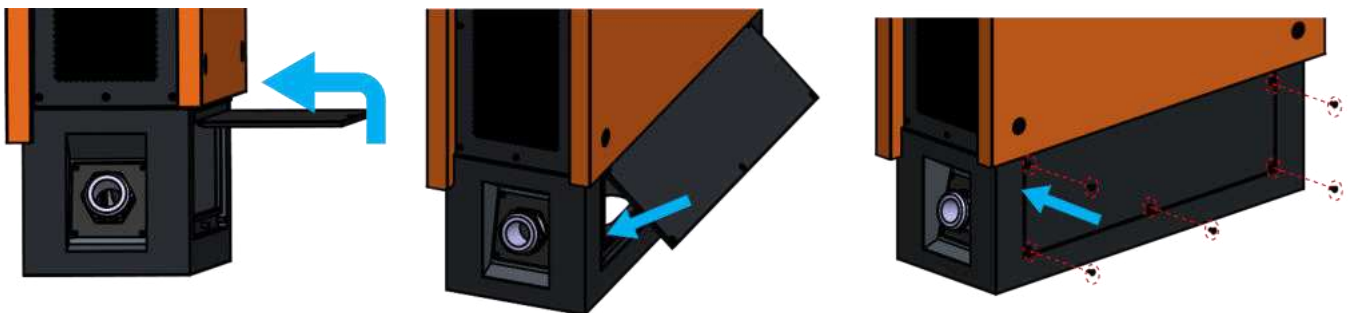

NOTE :

- Before charging the charger, recheck all electrical connections after all wiring is complete.
- Once all the chargers are powered on, the LCD screen will display the status of the charger.

6. Charging Process

6.1. Charging Process

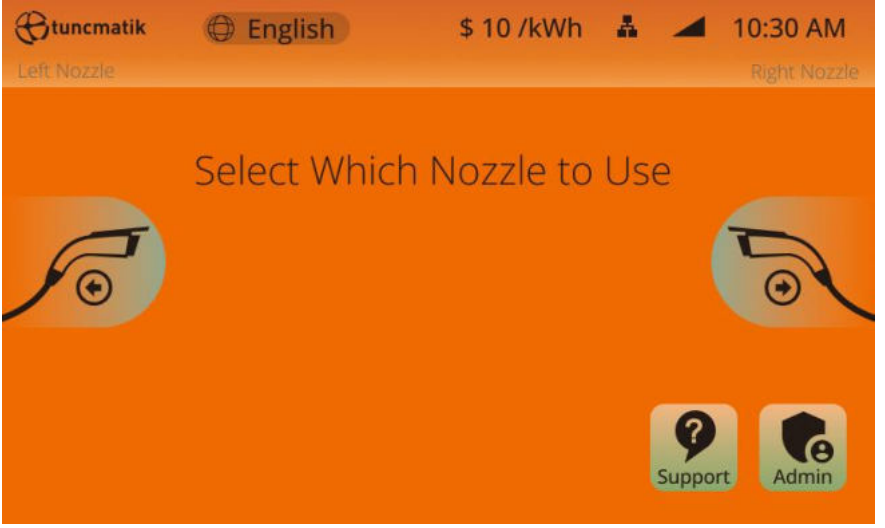
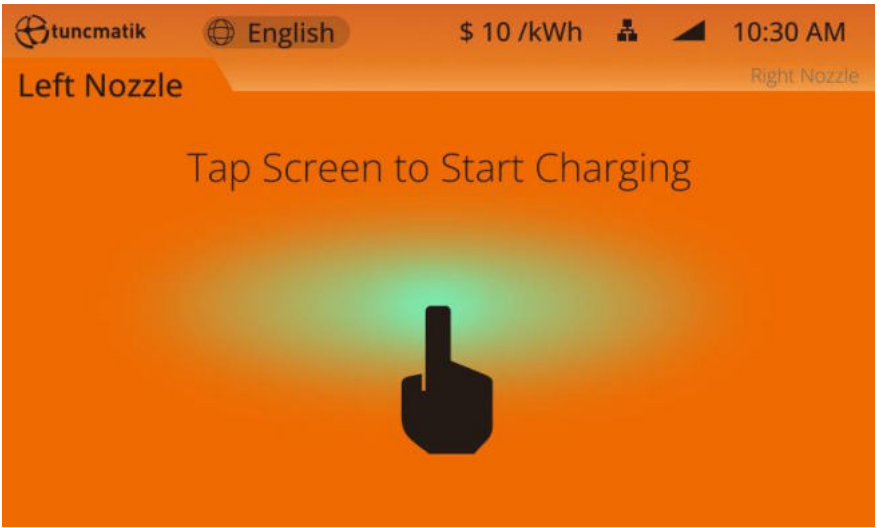
| Operating steps | Operating interface |
|--|--|
| <p>Step 1:</p> <ul style="list-style-type: none"> ● Select a nozzle on the screen (step 2-1) ● Insert the nozzle directly (step 2-2) |  <p>The screenshot shows the tuncmatik app interface. At the top, there is a status bar with the tuncmatik logo, 'English' language selection, '\$ 10 /kWh' price, signal strength, and '10:30 AM' time. Below the status bar, there are two tabs: 'Left Nozzle' and 'Right Nozzle'. The main content area has an orange background with the text 'Select Which Nozzle to Use' in the center. On either side of the text are circular icons representing a nozzle with a plus sign. At the bottom right, there are two buttons: 'Support' with a question mark icon and 'Admin' with a shield icon.</p> |
| <p>Step2-1 :</p> <p>Tap the screen (picture 1), the system will enter the waiting for card tapping interface (picture 2), after tapping the card, the system will enter the interface prompting to connect the nozzle. When the nozzle is connected, you can enter the interface for selecting the charging method (Step 3)</p> |  <p>The screenshot shows the tuncmatik app interface. At the top, there is a status bar with the tuncmatik logo, 'English' language selection, '\$ 10 /kWh' price, signal strength, and '10:30 AM' time. Below the status bar, there are two tabs: 'Left Nozzle' and 'Right Nozzle'. The main content area has an orange background with the text 'Tap Screen to Start Charging' in the center. Below the text is a large black hand icon with the index finger pointing up, indicating a tap gesture.</p> |

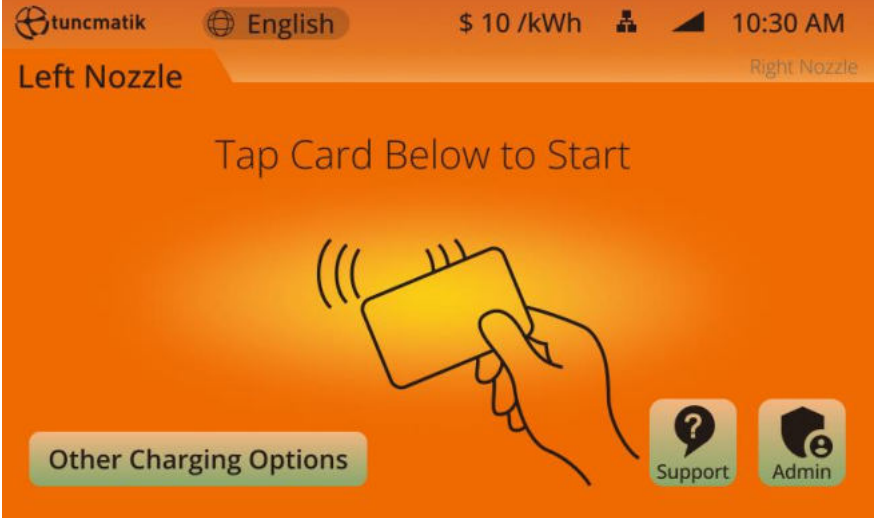
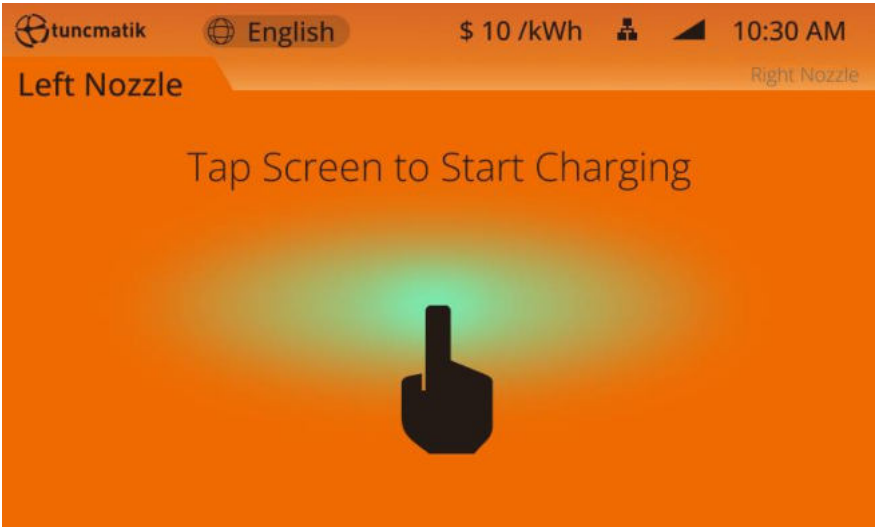
| | |
|--|--|
| |  <p> tuncmatik English \$ 10 /kWh 10:30 AM Left Nozzle Right Nozzle Tap Card Below to Start Other Charging Options Support Admin </p> |
| <p>Step 2-2: After the nozzle is connected, you will be prompted to tap the screen (picture 1) and then tap the card (picture 2). After tapping the card, you can enter the interface for selecting the charging method (Step 3)</p> |  <p> tuncmatik English \$ 10 /kWh 10:30 AM Left Nozzle Right Nozzle Tap Screen to Start Charging </p> |

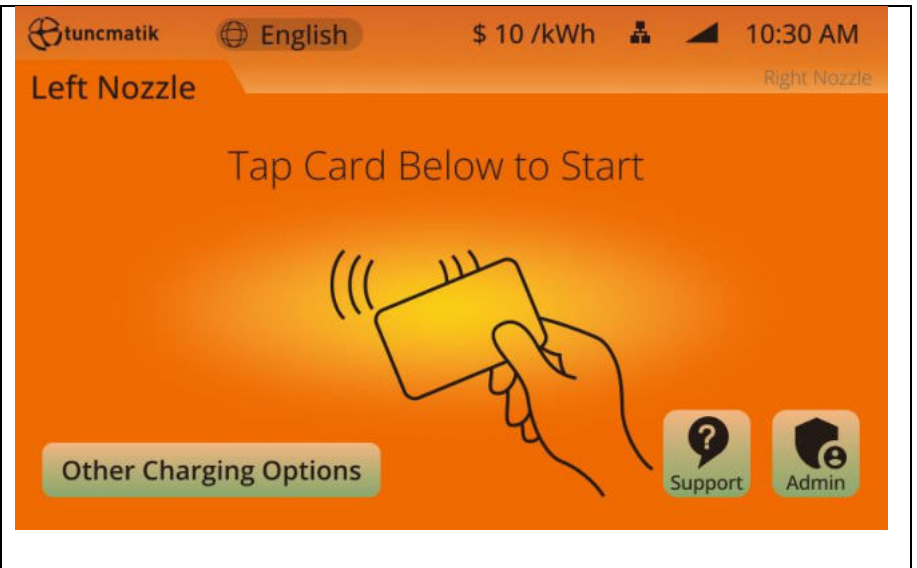
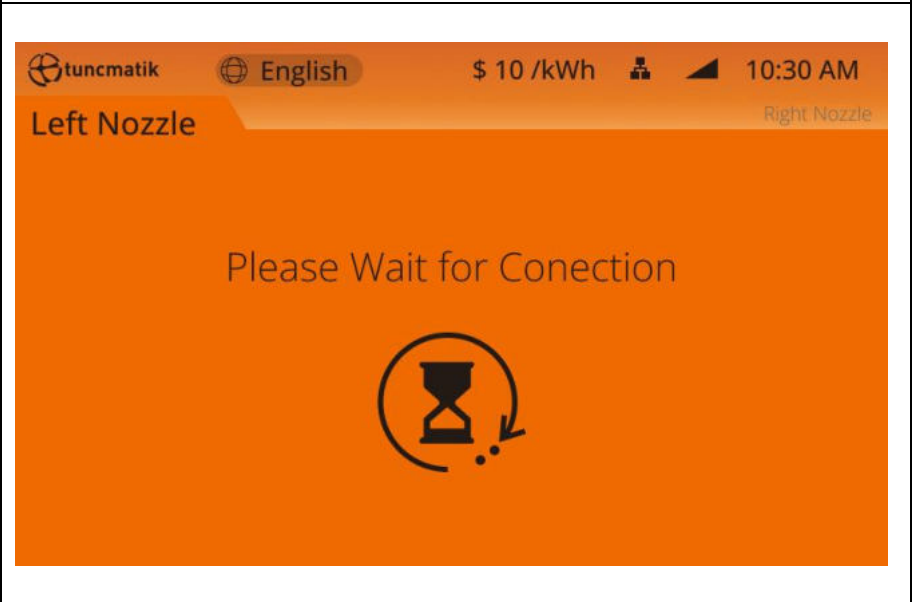
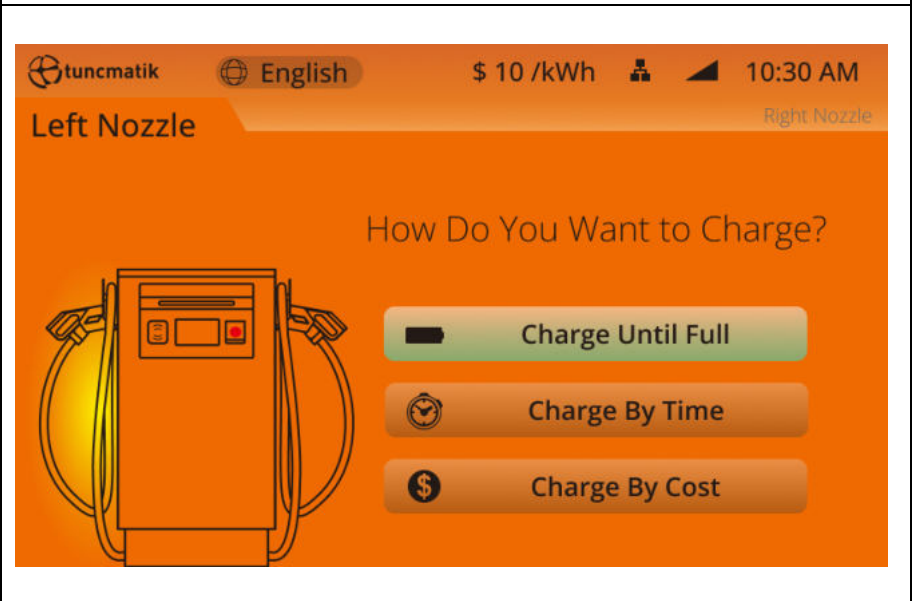
| | |
|---|--|
| |  |
| <p>Note: It takes a while to connect the nozzle.</p> |  |
| <p>Step 3: Select charging method: auto full, charge by time, or charge by cost.</p> |  |

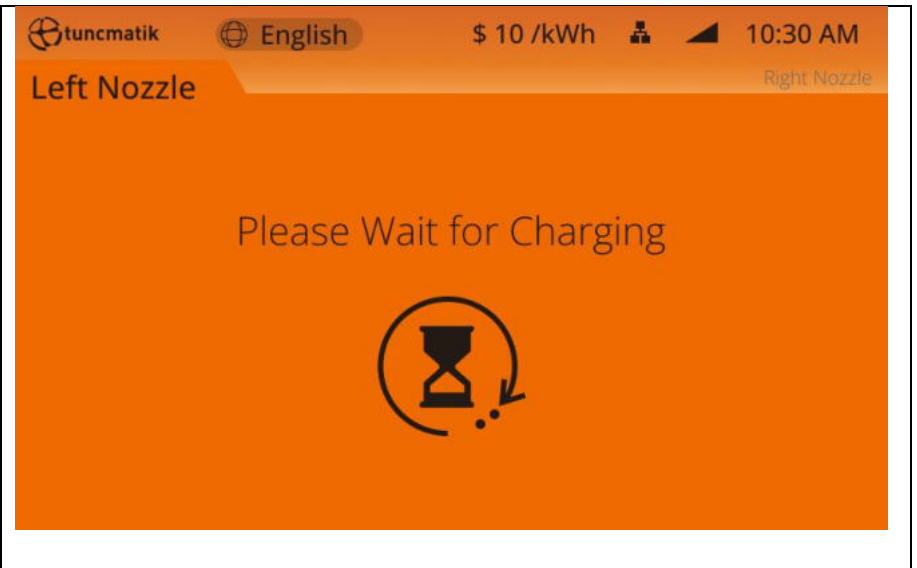
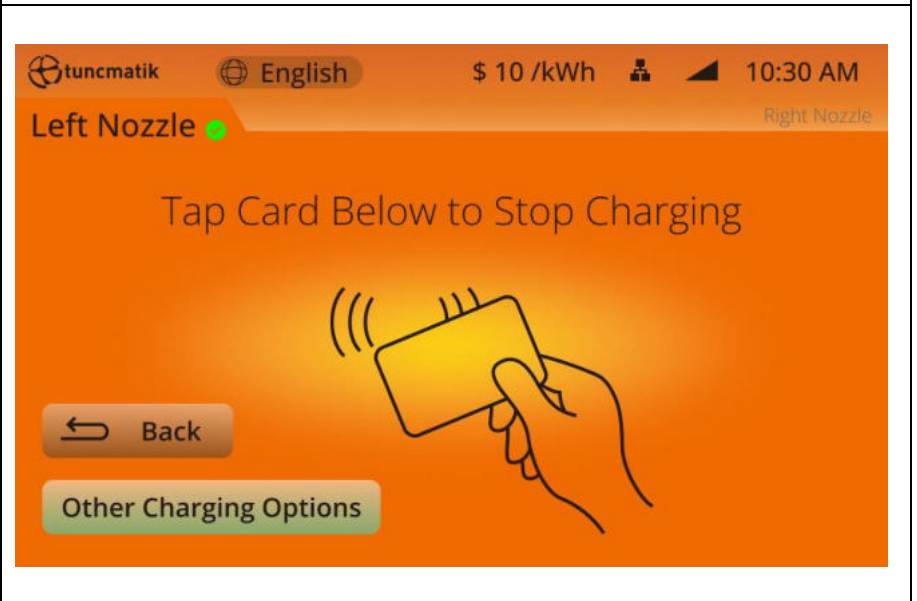
| | |
|---|---|
| <p>Step 4: Once the authorization is complete, this charger will start charging.</p> |  <p>The screenshot shows the top status bar with 'tuncmatik', 'English', '\$ 10 /kWh', and '10:30 AM'. Below the status bar, the text 'Left Nozzle' is on the left and 'Right Nozzle' is on the right. The main display area has an orange background with the text 'Please Wait for Charging' and a circular icon containing an hourglass and a curved arrow.</p> |
| <p>Step 5: While the vehicle is charging, charging data can be viewed on the LCD screen via the touchscreen.</p> |  <p>The screenshot shows the same top status bar. The main display area features a large green progress ring with '80%' and a lightning bolt icon. Below the ring, it says '\$4.000 left'. To the right, there are two columns of data: '0h32m' and '\$16.000' in the top row; 'CCS' and '40.000 kWh' in the middle row; and '392.0 V' and '200.0 A' in the bottom row. At the bottom, there are two buttons: 'Change Charge Type...' and 'Stop Charging'.</p> |
| <p>Step 6: After the charging is completed, it will pop up message to ask for tap the card again and finish the charging. Please tap the card near the induction area.</p> |  <p>The screenshot shows the same top status bar. The main display area has the text 'Tap Card Below to Stop Charging' and an illustration of a hand tapping a yellow card. Below the illustration, there are two buttons: 'Back' and 'Other Charging Options'.</p> |

Step 7:
It will display the charging capacity, charging amount, and charging time as the final screen.
When charging is complete, put the charging plug back in place.

tuncmatik
English
\$ 10 /kWh
10:30 AM

Left Nozzle
Right Nozzle

Charging Complete

End Reason : (1) xxxxxxxx

| | | |
|---------|------------|--------------|
| 🕒 0h40m | 💰 \$20.000 | ⚡ 50.000 kWh |
|---------|------------|--------------|

Detailed Report
Done

NOTE: During charging period, if it's necessary to stop charging, simply touch "  Şarj İşlemini Durdur " icon on the right bottom corner.

6.2. Charging Page Description

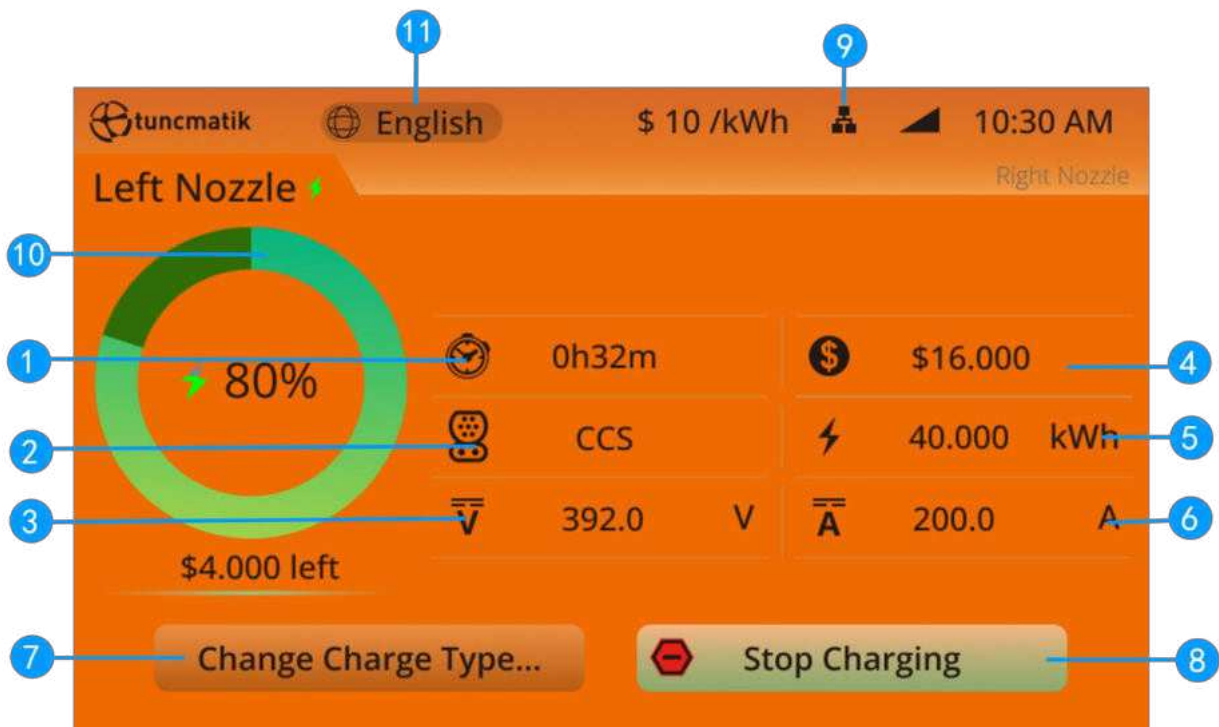

Figure 6-1 Real-time charging interface

1. Charging time
2. Nozzle type
3. Charging voltage
4. Charging cost

5. Charging capacity
6. Charging current
7. Change charge type
8. Stop button
9. Network status
10. Charging capacity of charged vehicle
11. Language selection



6.3. LED Operation



Idle

Charging

Fault

| Stare | Description | EV Pole LED |
|---------|-------------------|--|
| State A | (Idle) | / |
| State B | Vehicle Connected |  EV Green LED |
| State C | Charging |  EV Blue LED |
| State E | Fault |  EV Red LED |

6.4. Precautions

- If the screen shows a machine failure, do not operate, please contact the staff.
- When the charging light (green light) blinks, it is charging. At this time, please do not plug or unplug the charging gun to avoid electric shock.
- If it needs to be fully charged, please confirm that the balance of the IC card is sufficient when swiping the card. Charging will be automatically terminated if the balance is insufficient during

the charging process.

- Follow the charger's operating instructions when operating.
- Be careful not to overexert when unplugging the charging cable.
- In case of emergency, please press the emergency stop switch. Charging can not be carried out at this time.

6.5. EPO Operation

When any of the following situation occurs, please press EPO button to forcibly disconnect the AC contactor, and the control receives the EPO information to forcibly stop the charging processing, and provides a warning on the screen.

- Fire alarm, electric shock or leakage occurs on this charger
- Internal fault, can't stop charging, internal wiring problem occurs on this charger
- It's necessary to move charger location



NOTE: If you press the button by mistake, simply turn the button to the right to resume this action.

7. Routine Maintenance

Due to the influence of ambient temperature, humidity, dust and vibration, the internal devices of the charger will wear out, which leads to the potential failure of the charger. Therefore, it is necessary to carry out daily and regular maintenance of charger to ensure their normal operation and its service life.

- Regularly check if the cabinet structure is loose and sliding.
- Check if the connecting wire is worn and the charging connector is connected firmly.
- Regularly check if any internal components is damage, loose or burned out.
- Regularly check if AC incoming line and ground wire are firmly connected.
- Check the dust accumulation in the cabinet once a month and clean it in time to ensure the heat dissipation.
- Please be sure to keep the cabinet door closed and locked when nobody is on duty.

NOTE: Only professional electricians or persons with professional qualifications can operate the contents of this chapter.

| | |
|---|--|
|  | <p>CAUTION: Do not leave screws, washers and other metal parts in the charger for maintenance, otherwise the equipment may be damaged. After the completion of equipment maintenance, it is necessary to check the cabinet to ensure the normal operation of the charger.</p> |
|  | <p>Warning: During equipment maintenance and overhaul, please be sure to cut off the AC power supply of the charger.</p> |
|  | <p>Warning: During equipment maintenance, necessary measures shall be taken to prevent the charger from being energized by mistake.</p> |

| Maintenance Projects | Maintenance Cycle |
|--|-------------------|
| Check the function of each fan regularly: check whether there is abnormal noise and whether the fan turns smoothly. | 3 months |
| Regularly check the function of switches: switches, contactors and other switching devices in the circuit should be regularly checked to see if there is any damage or metal corrosion. | 3 months |
| Clean regularly: clean front and back door strainers and dustproof cotton. | 3 months |
| Check the cable and connection regularly, check whether all the cable connection is loose, if loose, must be tightened; Check connection terminals and insulation for discoloration or peeling, replace damaged or corroded terminals, and replace damaged cables. | 3 months |
| Check whether the warning label is firm or clear, and replace it accordingly. | 3 months |
| Regularly check whether there is abnormal sound during the operation of the charger. | 3 months |
| Check the emergency stop function regularly: check whether the emergency stop switch is normal. | 3 months |

NOTE: If the charger is used in a harsh environment, please carry out routine cleaning according to the actual usage.

8. Trouble Shooting

| Fault Code | Fault Description | Possible cause & What to do |
|-------------------|---|--|
| E015 | Charging gun is not in place | After charging, put the gun wire back in place |
| E017 | Failed to send bill | The charging station is connected to the background, and the bill is uploaded after charging, but no reply is received from the background, please contact the background. |
| E018 | Bill delivery timed out | The charging station is connected to the background, and the bill is uploaded after charging, but no reply is received from the background, please contact the background. |
| E026 | The charging condition reaches the user set value | When the charging condition reaches the set value (such as set time, set fee, set time, etc.), please pull out the gun and return to the original position. |
| E038 | BMS Demand Voltage Abnormal | BMS demand voltage exceeds its own maximum allowable charging voltage, please check the vehicle |
| E039 | Background Communication Abnormal | The charging station is set to background charging mode, but communication with the background is lost. Check network equipment. |
| E041 | Arrester failure | The arrester is damaged. Contact Customer Service |
| E042 | Overhaul of arrester | The arrester is damaged. Contact Customer Service |
| E043 | Emergency stop switch action | Please turn the E-STOP knob to enable the charger. If the second attempt to start fails, please call the customer service. |
| E044 | AC power loss | The AC circuit breaker has been disconnected. Check if the input is tripped. |
| E050 | Charging module AC overvoltage | Check if the AC input voltage is normal |
| E051 | AC undervoltage of charging module | Check if the AC input voltage is normal |
| E062 | Account does not exist | The card number (account number) is not recorded in the background, please record again. |
| E064 | The card has an unclosed record | Please return to the original charging station for settlement, or reissue the card. |
| E065 | Service password error | Please enter the correct password. |
| E080 | Vehicle Control Guidance Failure in Charging | The gun was pulled out during charging. |
| E100 | Active stop of vehicle | The Charging station received the BST message and thought that the vehicle stopped voluntarily. |
| E102 | Insufficient maximum output capacity of charger | The BMS required voltage exceeds the maximum output voltage of the charger. Replace the module with a higher voltage level |