



**Tuncmatik Ultra One Series  
300-400-500-600 kVA ONLINE  
UNINTERRUPTIBLE POWER SUPPLY  
USER MANUAL**

# Contents

<b>1. Safety</b> .....	2
<b>1.1 Safety notes</b> .....	2
<b>1.2 Symbols used in this guide</b> .....	2
<b>2. Main Features</b> .....	3
<b>2.1 Summarization</b> .....	3
<b>2.2 Functions and Features</b> .....	3
<b>3. Installation</b> .....	4
<b>3.1 Unpack checking</b> .....	4
<b>3.2 The appearance of the product</b> .....	4
<b>3.3 Installation notes</b> .....	11
<b>3.4 External Protective Devices</b> .....	12
<b>3.5 Power Cables</b> .....	12
<b>3.6 Power cable connect</b> .....	15
<b>3.7 Battery connection</b> .....	16
<b>3.8 UPS parallel Installation</b> .....	17
<b>3.8.1 Cabinet installation</b> .....	17
<b>3.8.2 Parallel cable installation</b> .....	18
<b>3.9 LBS installation (optional)</b> .....	18
<b>3.9.1 LCD setting</b> .....	18
<b>3.9.2 LBS cable installation</b> .....	18
<b>3.9.3 UPS installation</b> .....	19
<b>4. Operation</b> .....	20
<b>4.1 Operation Modes</b> .....	20
<b>4.2 Turn on/off UPS</b> .....	22
<b>4.2.1 Restart procedure</b> .....	22
<b>4.2.2 Test procedure</b> .....	22
<b>4.2.3 Cold start procedure</b> .....	22
<b>4.2.4 MAINTENANCE BYPASS</b> .....	23
<b>4.2.5 Shut down procedure</b> .....	24
<b>4.2.6 Startup procedure for parallel system</b> .....	24
<b>4.3 The Display</b> .....	25
<b>4.4 Display Messages/Troubleshooting</b> .....	54
<b>4.5 Options</b> .....	57
<b>Appendix 1 Specifications</b> .....	58
<b>Appendix 2 Problems and Solution</b> .....	60
<b>Appendix 3 CAN communication port definition</b> .....	61
<b>Appendix 4 RS485 communication port definition</b> .....	62
<b>Appendix 5 BAT_T communication port definition</b> .....	63
<b>Appendix 6 LBS port definition</b> .....	64
<b>Appendix 7 REPO instruction</b> .....	64

# 1. Safety

Important safety instructions – Save these instructions

There exists dangerous voltage and high temperature inside the UPS. During the installation, operation and maintenance, please abide the local safety instructions and relative laws, otherwise it will result in personnel injury or equipment damage. Safety instructions in this manual act as a supplementary for the local safety instructions. Our company will not assume the liability that caused by disobeying safety instructions.

## 1.1 Safety notes

1. Even no connection with utility power, 220/230/240VAC voltage may still exist at UPS outlet!
2. For the sake of human being safety, please well earth the UPS before starting it.
3. Don't open or damage battery, for the liquid spilled from the battery is strongly poisonous and do harmful to body!
4. Please avoid short circuit between anode and cathode of battery, otherwise, it will cause spark or fire!
5. Don't disassemble the UPS cover, or there may be an electric shock!
6. Check if there exists high voltage before touching the battery
7. Working environment and storage way will affect the lifetime and reliability of the UPS. Avoid the UPS from working under following environment for long time
  - ◆ Area where the humidity and temperature is out of the specified range (temperature 0 to 40°C, relative humidity 5%-95%)
  - ◆ Direct sunlight or location nearby heat
  - ◆ Vibration Area with possibility to get the UPS crashed.
  - ◆ Area with erosive gas, flammable gas, excessive dust, etc
8. Keep ventilations in good conditions otherwise the components inside the UPS will be over-heated which may affect the life of the UPS.

## 1.2 Symbols used in this guide



### **WARNING!**

Risk of electric shock



### **CAUTION!**

Read this information to avoid equipment damage

## 2. Main Features

### 2.1 Summarization

This series UPS is a kind of three-in-three-out high frequency online UPS, it provides seven specifications: The 300~600kVA. The UPS can solve most of the power supply problems, such as blackout, over-voltage, under-voltage, voltage sudden drop, oscillating of decreasing extent, high voltage pulse, voltage fluctuation, surge, inrush current, harmonic distortion (THD), noise interference, frequency fluctuation, etc..

This UPS can be applied to different applications from computer device, automatic equipment, communication system to industry equipment.

### 2.2 Functions and Features

#### ◆ 3Phase In/3Phase Out UPS

It is 3Phase In/3Phase Out high-density UPS system, of which input current is kept in balance. No unbalance problem might occur.

#### ◆ Digital Control

This series UPS is controlled by Digital Signal Processor (DSP); enhance, it increases reliability, performance, self-protection, and self-diagnostics and so on.

#### ◆ Battery Configurable from 30blocks to 50 blocks

The battery voltage of this series UPS can be configured at 30 blocks, 32 blocks, 34 blocks, 36 blocks, 38 blocks, 40 blocks, 42 blocks, 44 blocks, 46 blocks, 48 blocks or 50 blocks according to your convenience.

#### ◆ Charging Current is configurable

The user may set the capacity of the batteries as well as reasonable charging current. Constant voltage mode, constant current mode or floating mode can be switched automatically and smoothly.

#### ◆ Intelligent charging Method

The series UPS adopts advanced three-stage charging method—

1<sup>st</sup> stage: high current constant current charging

To guarantee to charge back to 90%;

2<sup>nd</sup>-stage: Constant Voltage

In order to vitalize battery and make sure batteries are fully charged

3<sup>rd</sup> stage: floating mode.

With this 3-stage charging method, it extends the life of the batteries and guarantees fast charging.

#### ◆ Intelligent Monitoring Function

Via optional SNMP Card, you may remotely control and monitor the UPS.

#### ◆ Touch-screen Super-large LCD display

#### ◆ Equip with Maintenance Bypass Switch for easy maintenance purpose.

#### ◆ Superior MTTR (Meantime to repair) & Short shutdown time in maintenance

#### ◆ Centralized monitoring module is also available

#### ◆ EPO and REPO function

## 3. Installation

### 3.1 Unpack checking

1. Don't lean the UPS when moving it out from the packaging
2. Check the appearance to see if the UPS is damaged or not during the transportation, do not switch on the UPS if any damage found. Please contact the dealer right away.
3. Check the accessories according to the packing list and contact the dealer in case of missing parts.

### 3.2 The appearance of the product

#### 300kVA (Full configuration)

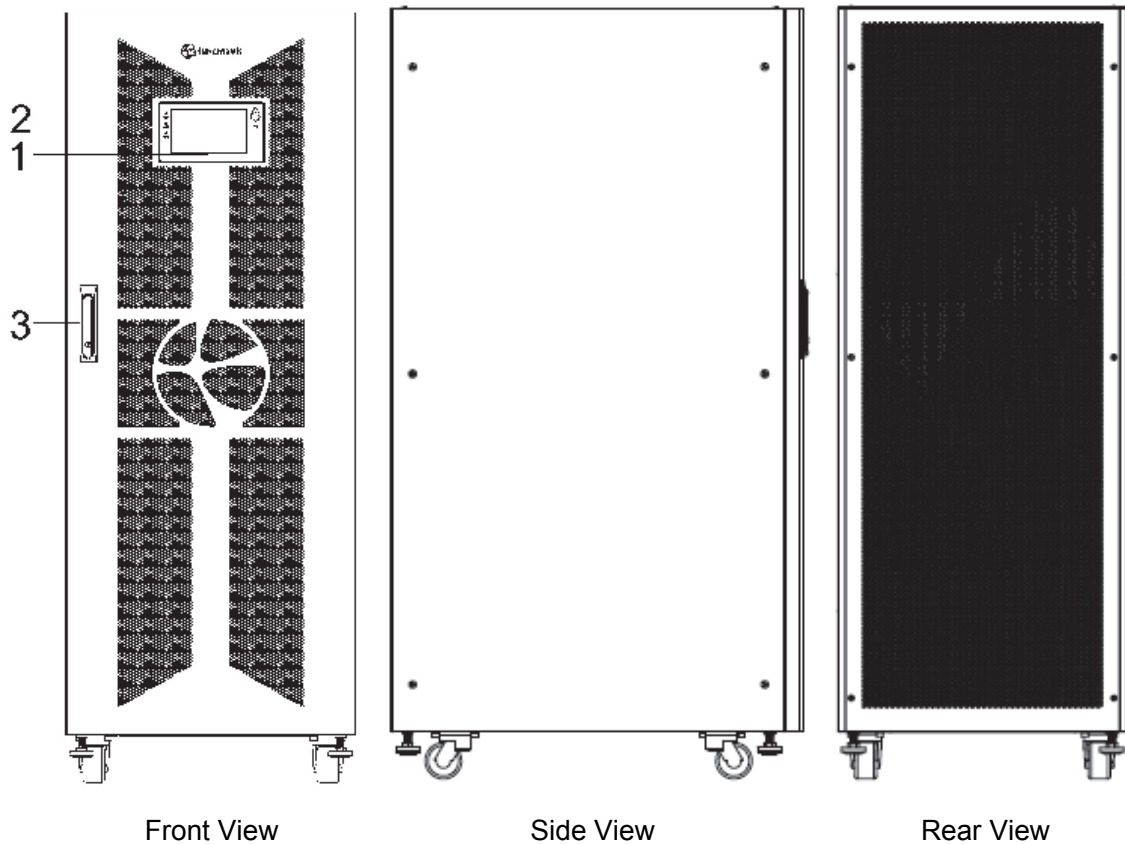

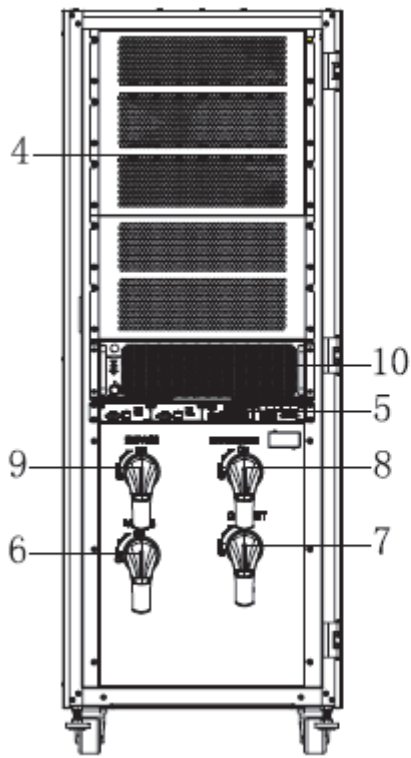

Front View (internal)

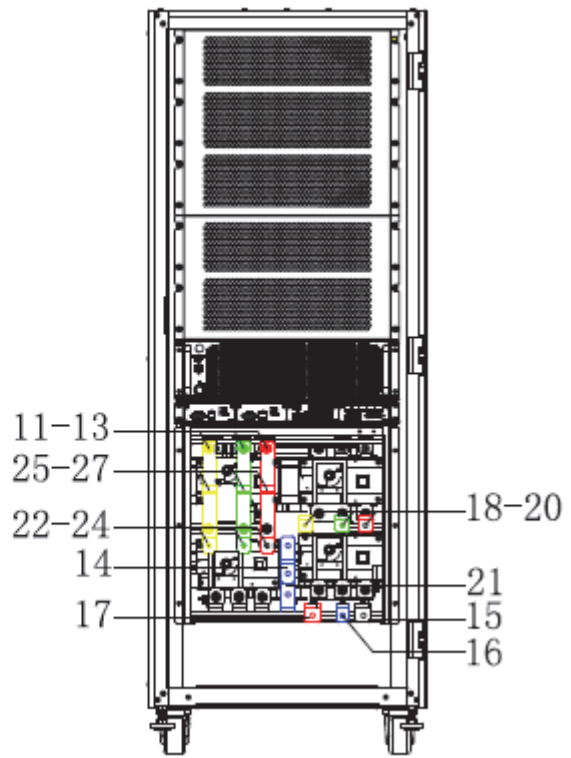

Front View (Copper bar)

**400kVA (Full configuration)**

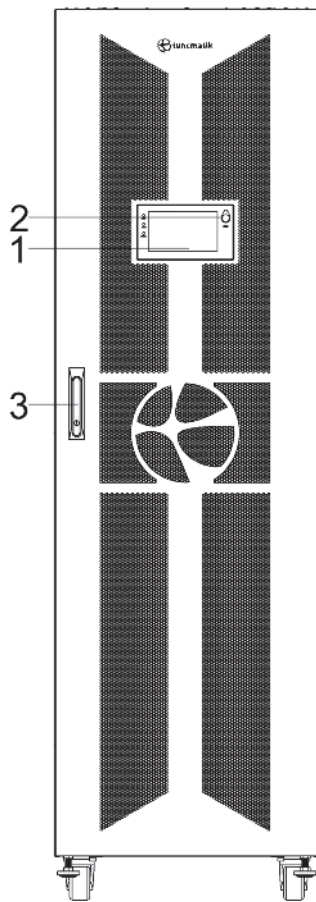

Front View

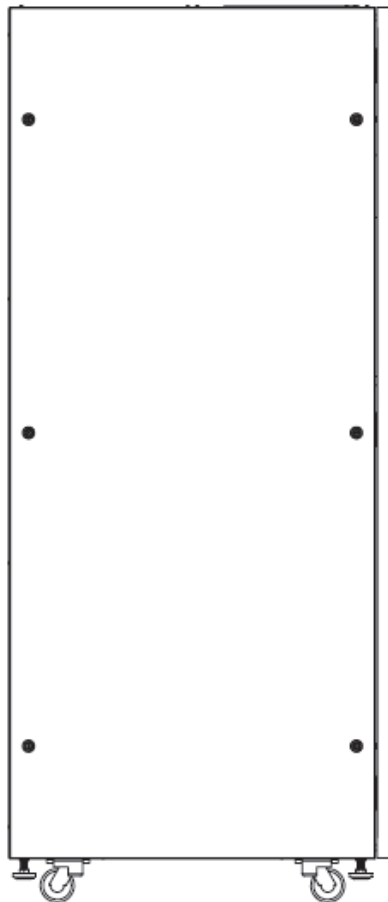

Side View

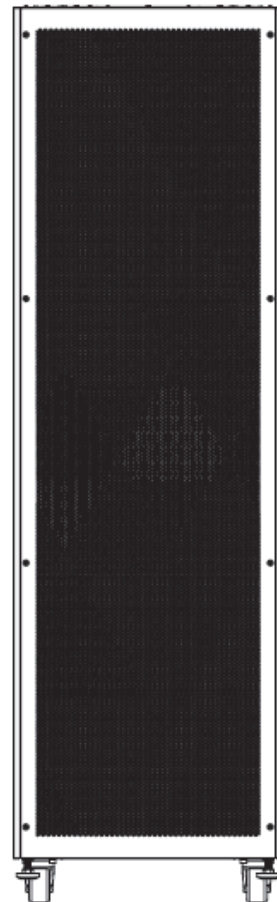

Rear View

**400kVA (Full configuration)**

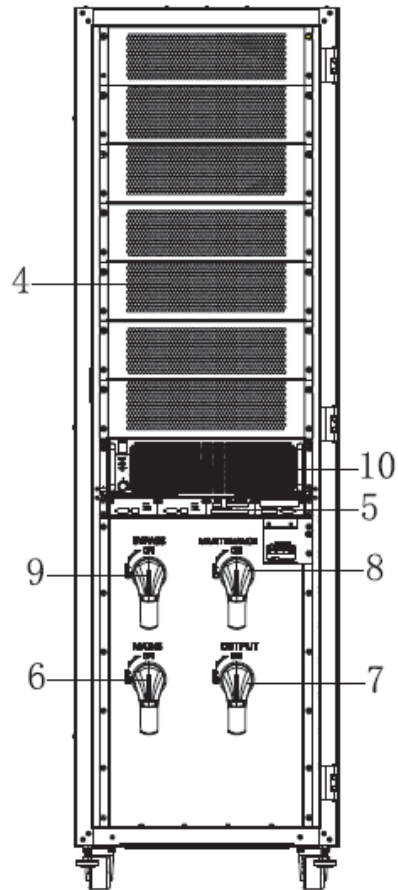

Front View (internal)

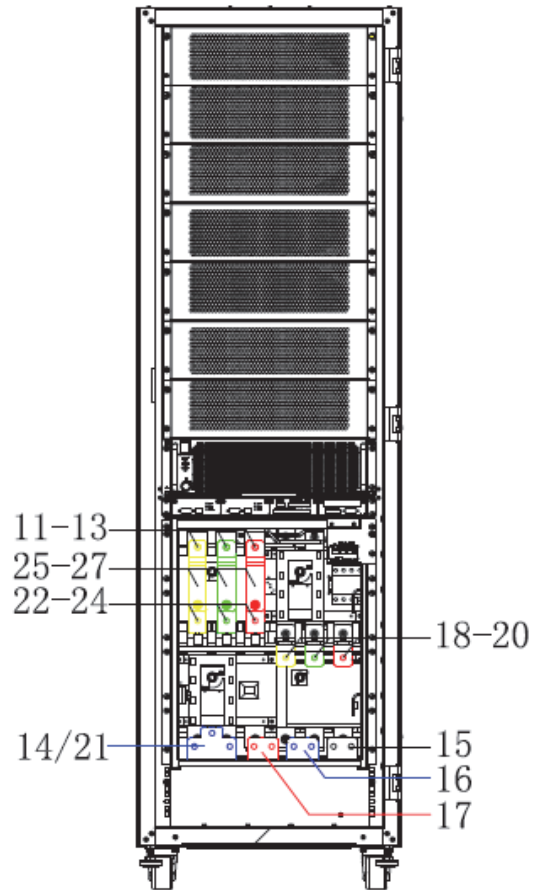

Front View (Copper bar)

**500/600kVA (Full configuration)**

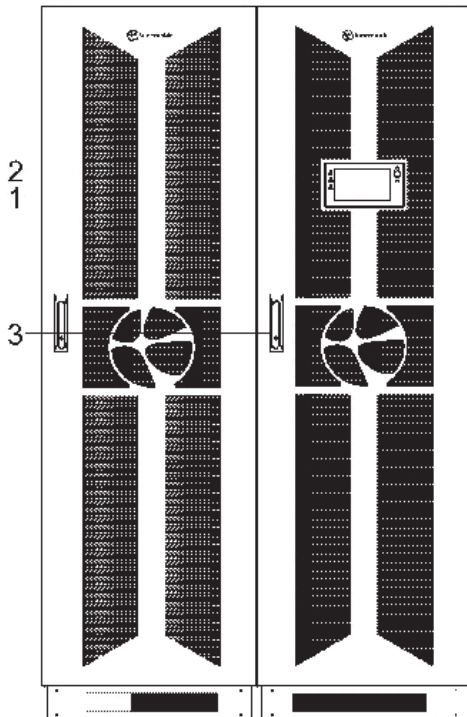

Front View

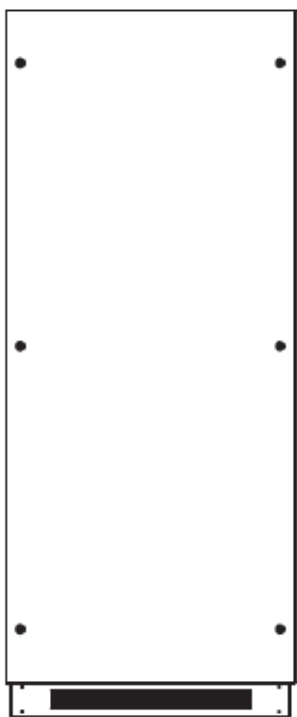

Side View

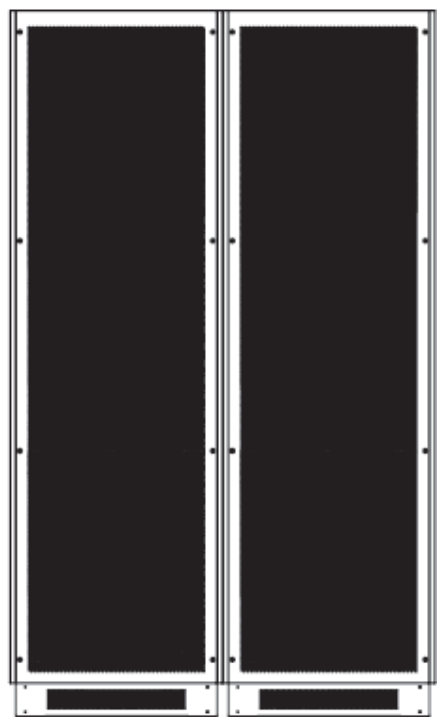

Rear View

500kVA (Full configuration)

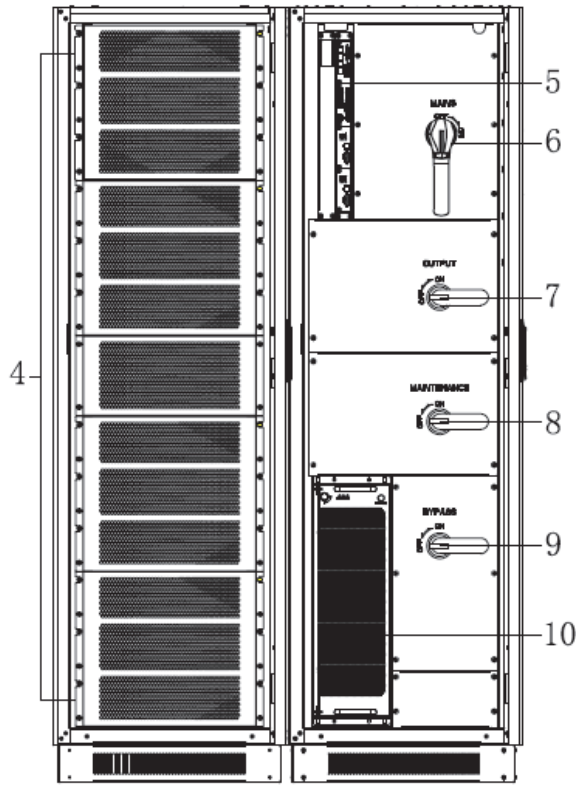

Full configuration

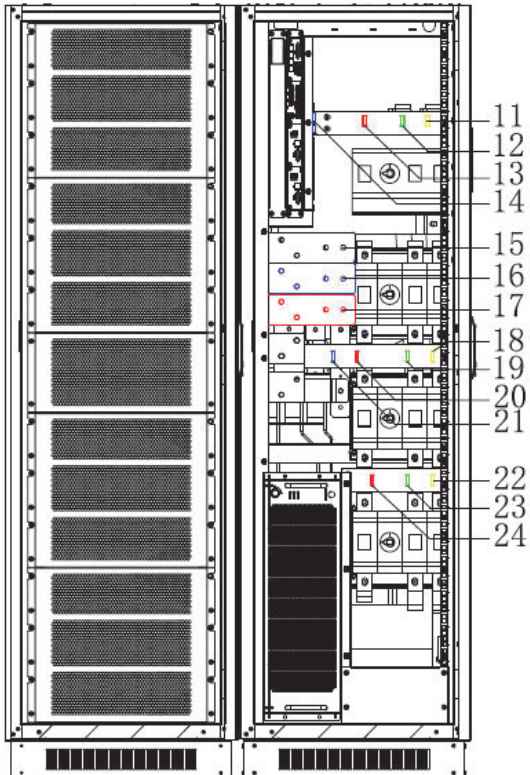

Connect copper bar

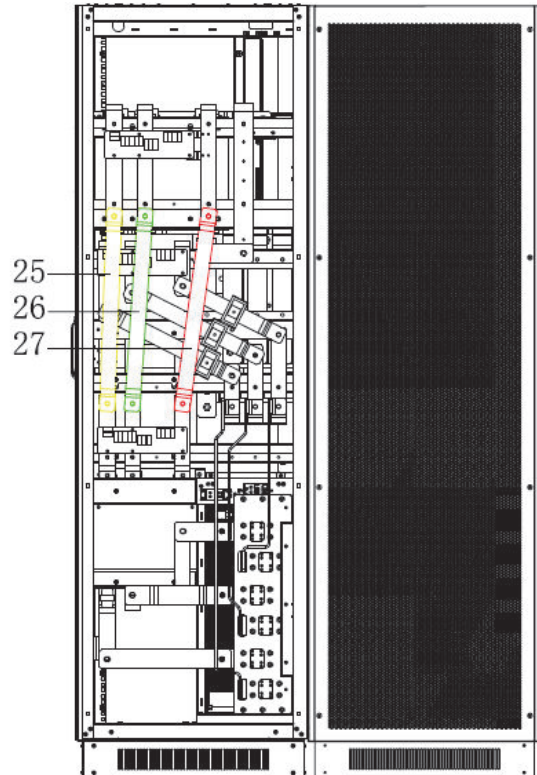

Mains-bypass common copper bar

**600kVA (Full configuration)**

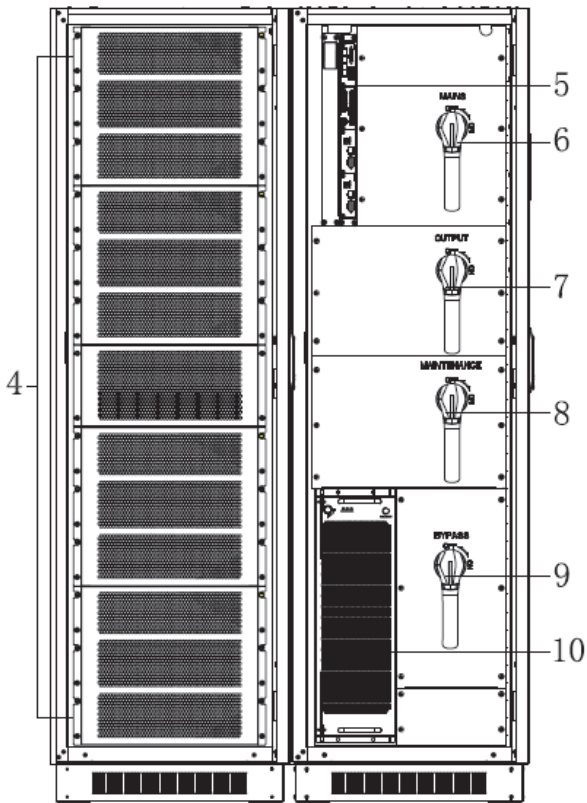

Full configuration

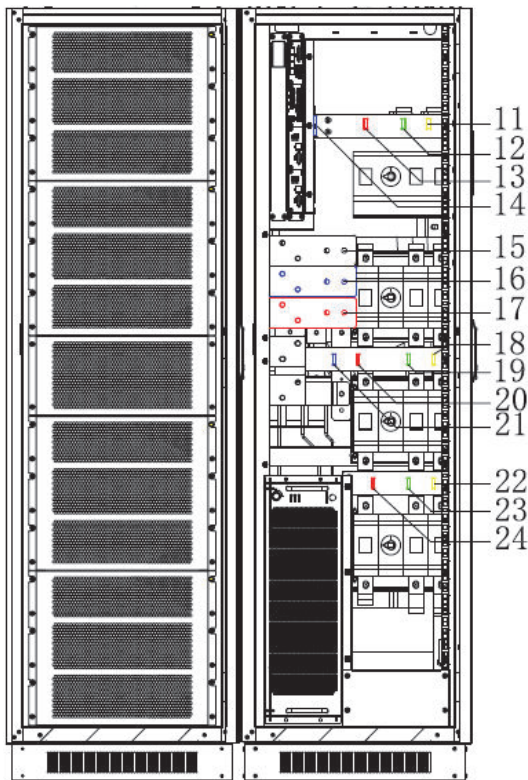

Connect copper bar

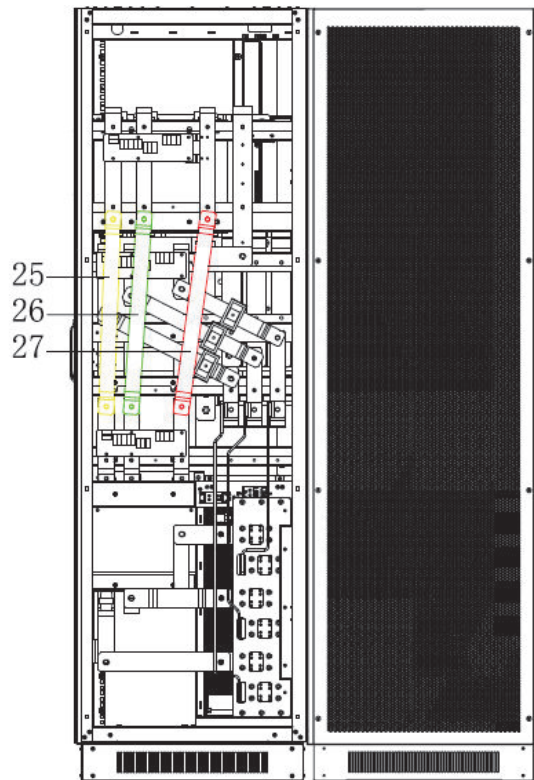

Mains-bypass common copper bar

(1) LCD panel : Display UPS data and status

(2) EPO button

(3) Door lock

- (4) Dustproof net plate
- (5) Control unit
- (6) Mains switch
- (7) Output switch
- (8) Maintenance switch
- (9) Bypass switch
- (10) Bypass module
- (11) Mains-A input copper bar
- (12) Mains-B input copper bar
- (13) Mains-C input copper bar
- (14) Input neutral copper bar
- (15) Battery negative copper bar
- (16) Battery neutral copper bar
- (17) Battery positive copper bar
- (18) Output-A input copper bar
- (19) Output-B input copper bar
- (20) Output-C input copper bar
- (21) Output neutral copper bar
- (22) Bypass-A input copper bar : Wiring must be used when mains-bypass separation
- (23) Bypass-B input copper bar : Wiring must be used when mains-bypass separation
- (24) Bypass-C input copper bar : Wiring must be used when mains-bypass separation
- (25) Phase A mains-bypass common input connect copper bar
- (26) Phase B mains-bypass common input connect copper bar
- (27) Phase C mains-bypass common input connect copper bar

**Control unit**

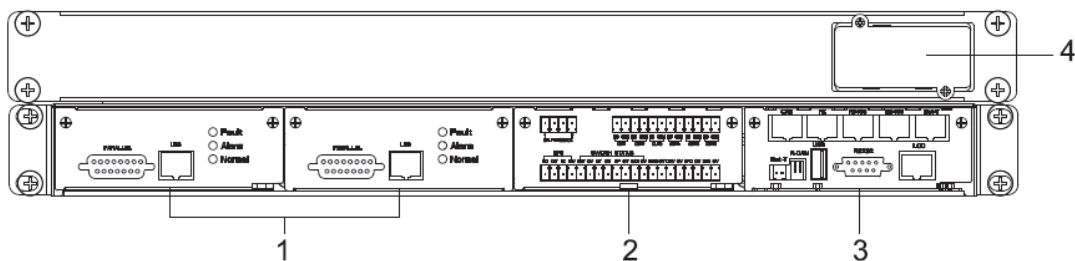

- (1) ECU1/2 : Centralized control unit
- (2) Dry-contact unit
- (3) monitor unit
- (4) Intelligent slot

## ECU unit

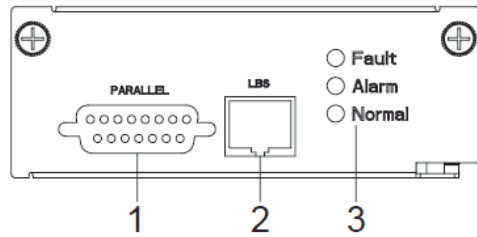

(1) PARALLEL port

(2) LBS port

(3) LED

## Dry-contact unit

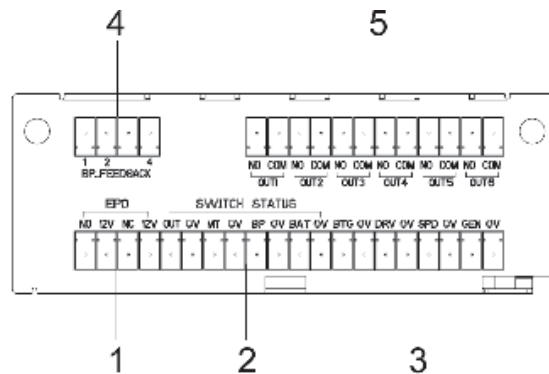

(1) EPO port : NO-12V : normally open port; NC-12V : normally close port;

(2) SWITCH STATUS : OUT-0V : output breaker auxiliary contact signal port; MT-0V : maintenance breaker auxiliary contact signal port; BP-0V : bypass breaker auxiliary contact signal port; BAT-0V : battery breaker auxiliary contact signal port;

(3) The other port : BTG-0V : battery grounding detect signal input port; DRV-0V : battery breaker driver signal output port; SPD-0V : SPD detect signal input port; GEN-0V : generator detect signal input port;

(4) BP\_FEEDBACK : PIN1\_NC, PIN2\_NO, PIN4\_common

(5) Optional dry contacts : 6 ports, can optional by LCD.

## Monitor unit

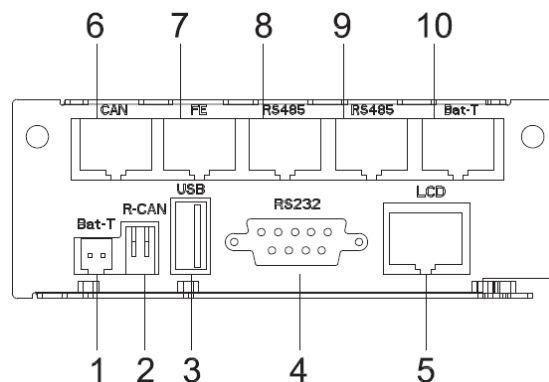

(1) BAT\_T : NTC temperature sensor port

(2) R-CAN : CAN communication resistor adjust

(3) USB port : for software update and history download

- (4) RS232 port : for communication

---

- (5) LCD port

---

- (6) CAN port : BMS port

---

- (7) FE : Net port (reserve)

---

- (8) RS485 port: for communication

---

- (9) RS485 port: for communication

---

- (10) BAT\_T : battery temperature sensor port (RS485)

---

### 3.3 Installation notes

Note: Consider for the convenience of operation and maintenance, the space in front and back of the cabinet should be left at least 800mm and 800mm respectively when installing the cabinet.

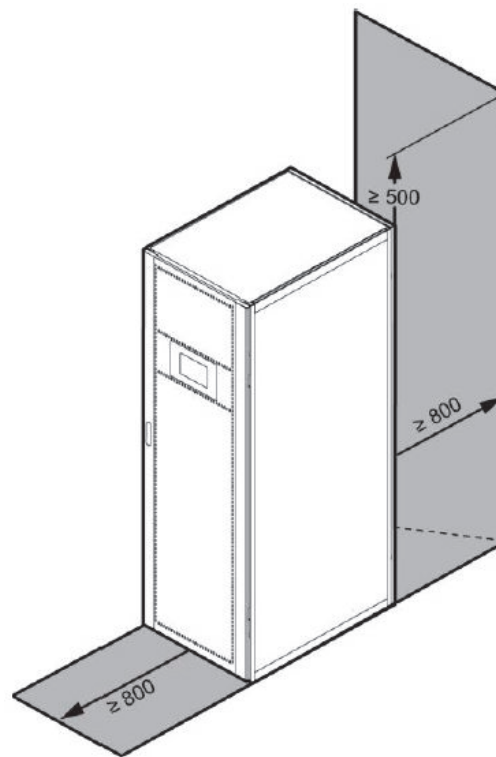

◆ Please place the UPS in a clean, stable environment; avoid the vibration, dust, humidity, flammable gas and liquid, corrosive. To avoid from high room temperature, a system of room extractor fans is recommended to be installed. Optional air filters are available if the UPS operates in a dusty environment.

◆ The environment temperature around UPS should keep in a range of 0°C~40°C. If the environment temperature exceeds 40°C, the rated load capacity should be reduced by 12% per 5°C. The max temperature can't be higher than 50°C.

◆ If the UPS is dismantled under low temperature, it might be in a condensing condition. The UPS can't be installed unless the internal and external of the equipment is fully dry. Otherwise, there will be in danger of electric shock.

◆ Batteries should be mounted in an environment where the temperature is within the required specs. Temperature is a major factor in determining battery life and capacity. In a normal installation, the battery temperature is maintained between 15°C and 25°C. Keep batteries away from heat sources or main air ventilation area, etc.



### **WARNING!**

Typical battery performance data are quoted for an operating temperature between 20°C and 25°C. Operating it above this range will reduce the battery life while operation below this range will reduce the battery capacity.

◆ Should the equipment not be installed immediately it must be stored in a room so as to protect it against excessive humidity and or heat sources.



### **CAUTION!**

An unused battery must be recharged every 6 months temporarily connecting the UPS to a suitable AC supply mains and activating it for the time required for recharging the batteries.

◆ The highest altitude that UPS may work normally with full load is 1500 meters. The load capacity should be reduced when this UPS is installed in place whose altitude is higher than 1500 meters, shown as the following table:

(Load coefficient equals max load in high altitude place divided by nominal power of the UPS)

Altitude(m)	1500	2000	2500	3000	3500	4000	4500	5000
Load coefficient	100%	95%	90%	85%	80%	75%	70%	65%

◆ The UPS cooling is depending on fan, so it should be kept in good air ventilation area. There are many ventilation holes on the front and rear, so they should not be blocked by any exotic obstacles.

## **3.4 External Protective Devices**

For safety reasons, it is necessary to install, external circuit breaker at the input A.C. supply and the battery. This chapter provides guidelines for qualified installers that must have the knowledge of local wiring practices for the equipment to be installed.

### **◆ External Battery**

The UPS and its associated batteries are protected against the effect of over-current through a DC compatible thermo-magnetic circuit-breaker (or a set of fuses) located close to the battery.

### **◆ UPS Output**

Any external distribution board used for load distribution shall be fitted with protective devices that may avoid the risk of UPS overloaded.

### **◆ Over-current**

Protection device shall be installed at the distribution panel of the incoming main supply. It may identify the power cables current capacity as well as the overload capacity of the system.

## **3.5 Power Cables**

◆ The cable design shall comply with the voltages and currents provided in this section, Kindly follow local wiring practices and take into consideration the environmental conditions (temperature and physical support media).

## WARNING!



UPON STARTING, PLEASE ENSURE THAT YOU ARE AWARE OF THE LOCATION AND OPERATION OF THE EXTERNAL ISOLATORS WHICH ARE CONNECTED TO THE UPS INPUT/BYPASS SUPPLY OF THE MAINS DISTRIBUTION PANEL. CHECK TO SEE IF THESE SUPPLIES ARE ELECTRICALLY ISOLATED, AND POST ANY NECESSARY WARNING SIGNS TO PREVENT ANY INADVERTENT OPERATION

### 3.5.1 Recommended cross-sectional areas for power cables

- ◆ For future expansion purpose, it is economical to install power cable according to the full rating capacity initially. The diameter of cable is shown below:

UPS cabinet	Cable Dimension				
	AC Input (mm <sup>2</sup> )	BPS Input (mm <sup>2</sup> )	AC Output (mm <sup>2</sup> )	DC Input (mm <sup>2</sup> )	Grounding (mm <sup>2</sup> )
300	120*2	120*2	120*2	150*2	120
400	185*2	150*2	150*2	240*2	150
500	150*3	240*2	240*2	185*3	240
600	240*3	150*3	150*3	240*3	240

- ◆ When selecting, connecting, and routing power cables, follow local safety regulations and rules.
- ◆ If external conditions such as cable layout or ambient temperatures change, perform verification in accordance with the IEC-60364-5-52 or local regulations.
- ◆ If the rated voltage is 400 V, multiply the currents by 0.95. If the rated voltage is 415 V, multiply the currents by 0.92.
- ◆ If primary loads are non-linear loads, increase the cross-sectional areas of neutral wires 1.5–1.7 times.
- ◆ The nominal battery discharge current refers to the current of forty 12 V batteries at 480V in standard configuration.
- ◆ The maximum battery discharge current refers to the current when forty 12 V batteries in standard configuration, that is, two hundred and forty 2 V battery cells (1.67 V/cell), stop discharging.
- ◆ The battery cable specifications are selected based on 40 batteries by default and compatible with application scenarios with 30–50 batteries.
- ◆ When the mains input and bypass input share a power source, configure both types of input power cables as mains input power cables. The cables listed in Table are used only when the following requirements are met:
  - Routing mode: Routing the cables over the cable ladder or bracket in a single layer (IEC60364-5-52 middle E).
  - The ambient temperature is 30°C.
  - The AC voltage loss is less than 3%, and the DC voltage loss is less than 1%.
  - 90°C copper flexible cable.
  - The length of the AC power cables of a UPS is no longer than 30 m and DC power cables no longer than 50 m.

### 3.5.2 Power cable connector requirements

Model	Connector	Connection Mode	Bolt Type	Bolt Hole Diameter	Torque
300k	Mains input connector	Crimped OT terminals	M12	13.5mm	78N•m
	Bypass input connector	Crimped OT terminals	M12	13.5mm	78N•m
	Battery input connector	Crimped OT terminals	M12	13.5mm	78N•m
	Output connector	Crimped OT terminals	M12	13.5mm	78N•m
	Grounding connector	Crimped OT terminals	M12	13.5mm	78N•m
400k	Mains input connector	Crimped OT terminals	M12	13.5mm	78N•m
	Bypass input connector	Crimped OT terminals	M12	13.5mm	78N•m
	Battery input connector	Crimped OT terminals	M12	13.5mm	78N•m
	Output connector	Crimped OT terminals	M12	13.5mm	78N•m
	Grounding connector	Crimped OT terminals	M12	13.5mm	78N•m
500k	Mains input connector	Crimped OT terminals	M12	13.5mm	78N•m
	Bypass input connector	Crimped OT terminals	M12	13.5mm	78N•m
	Battery input connector	Crimped OT terminals	M12	13.5mm	78N•m
	Output connector	Crimped OT terminals	M12	13.5mm	78N•m
	Grounding connector	Crimped OT terminals	M12	13.5mm	78N•m
600k	Mains input connector	Crimped OT terminals	M12	13.5mm	78N•m
	Bypass input connector	Crimped OT terminals	M12	13.5mm	78N•m
	Battery input connector	Crimped OT terminals	M12	13.5mm	78N•m
	Output connector	Crimped OT terminals	M12	13.5mm	78N•m
	Grounding connector	Crimped OT terminals	M12	13.5mm	78N•m

### 3.5.3 Recommended input front-end and output back-end circuit breakers

UPS capacity	Component	Specifications
300k	Mains input circuit breaker	500A 3P
	Bypass input circuit breaker	500A 3P
	Output branch circuit breaker	500A 3P

400k	Mains input circuit breaker	800A 3P
	Bypass input circuit breaker	630A 3P
	Output branch circuit breaker	630A 3P
500k	Mains input circuit breaker	1000A 3P
	Bypass input circuit breaker	800A 3P
	Output branch circuit breaker	800A 3P
600k	Mains input circuit breaker	1250A 3P
	Bypass input circuit breaker	1250A 3P
	Output branch circuit breaker	1250A 3P



### CAUTION!

Protective earth cable: Connect each cabinet to the main ground system. For Grounding connection, follow the shortest route possible.



### WARNING!

FAILURE TO FOLLOW ADEQUATE EARTHING PROCEDURES MAY RESULT IN ELECTROMAGNETIC INTERFERENCE OR IN HAZARDS INVOLVING ELECTRIC SHOCK AND FIRE

## 3.6 Power cable connect

Before equipment has been installed, must confirm the input source type, common input or Split input, if the input source is dual input, must remove the copper bar that connected bypass and mains.

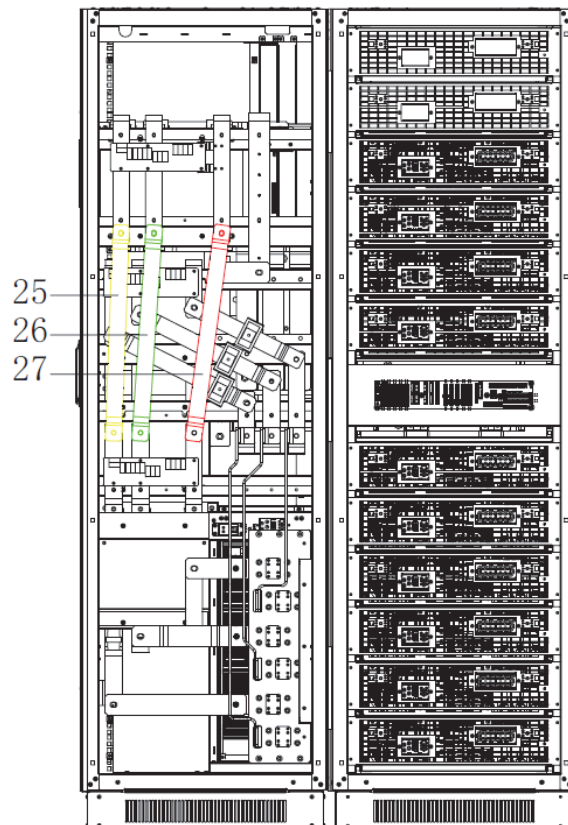

Choose appropriate power cable. (Refer to the table above) and pay attention to the diameter of the connection terminal of the cable that should be greater than or equal to that of the connection poles;

### Wiring

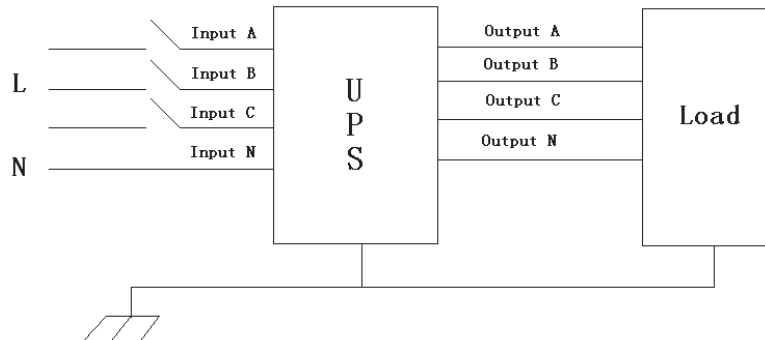

### WARNING!



If the load equipment is not ready to accept power on the arrival of the commissioning engineer then ensure that the system output cables are safely isolated at their ends

Connect the safety earth and any necessary bonding earth cables to the copper earth screw located on the floor of the equipment below the power connections. All cabinets in the UPS must be grounded properly.



### CAUTION!

The earthing and neutral bonding arrangement must be in accordance with local and national codes of practice.

## 3.7 Battery connection

The UPS adopts positive and negative double battery framework, total 30 (optional 32/34/36/38/40/42/44/46/48/50) in series. A neutral cable is retrieved from the joint between the cathode of the 15<sup>th</sup> (16<sup>th</sup>/17<sup>th</sup>/18<sup>th</sup>/19<sup>th</sup>/20<sup>th</sup>/21<sup>th</sup>/22<sup>th</sup>/23<sup>th</sup>/24<sup>th</sup>/25<sup>th</sup>) and the anode of the 16<sup>th</sup> (17<sup>th</sup>/18<sup>th</sup>/19<sup>th</sup>/20<sup>th</sup>/21<sup>th</sup>/22<sup>th</sup>/23<sup>th</sup>/24<sup>th</sup>/25<sup>th</sup>/26<sup>th</sup>) of the batteries. Then the neutral cable, the battery Positive and the battery negative are connected with the UPS respectively. The battery sets between the Battery anode and the neutral are called positive batteries and that between neutral and cathode are called negative ones. The user can choose the capacity and the numbers of the batteries according to their desire.

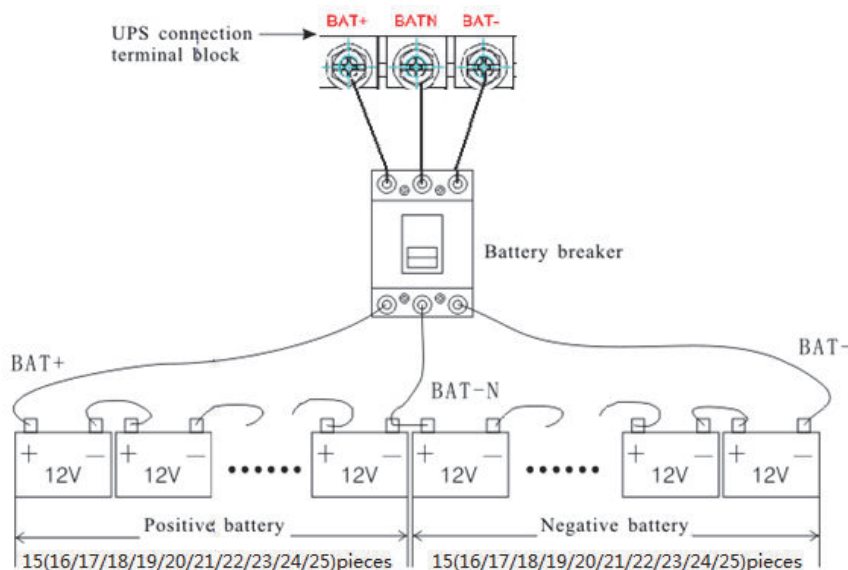

**Note:**

The BAT+ of the UPS connect poles is connected to the anode of the positive battery, the BAT-N is connected to the cathode of the positive battery and the anode of the negative battery, the BAT- is connected to the cathode of the negative battery.

Factory setting of the long-run unit is battery quantity---30pcs, battery capacity---12V 100AH. When connecting 32/34/36/38/40/42/44/46/48/50 batteries, please re-set desired battery quantity and its capacity after UPS starts at AC mode. Charger current could be adjusted automatically according to battery capacity selected. All related settings can be done through LCD panel or monitoring software.

**CAUTION!**



Ensure correct polarity battery string series connection. i.e. inter-tier and inter block connections are from (+) to (-) terminals.

Don't mix batteries with different capacity or different brands, or even mix up new and old batteries, either.

**WARNING!**



Ensure correct polarity of string end connections to the Battery Circuit Breaker and from the Battery Circuit Breaker to the UPS terminals i.e. (+) to (+) / (-) to (-) but disconnect one or more battery cell links in each tier. Do not reconnect these links and do not close the battery circuit breaker unless authorized by the commissioning engineer.

### 3.8 UPS parallel Installation

The basic installation procedure of a parallel system comprising of two or more UPS is the same as that of single system. The following sections introduce the installation procedures specified to the parallel system.

#### 3.8.1 Cabinet installation

Connect all the UPS needed to be put into parallel system as below picture.

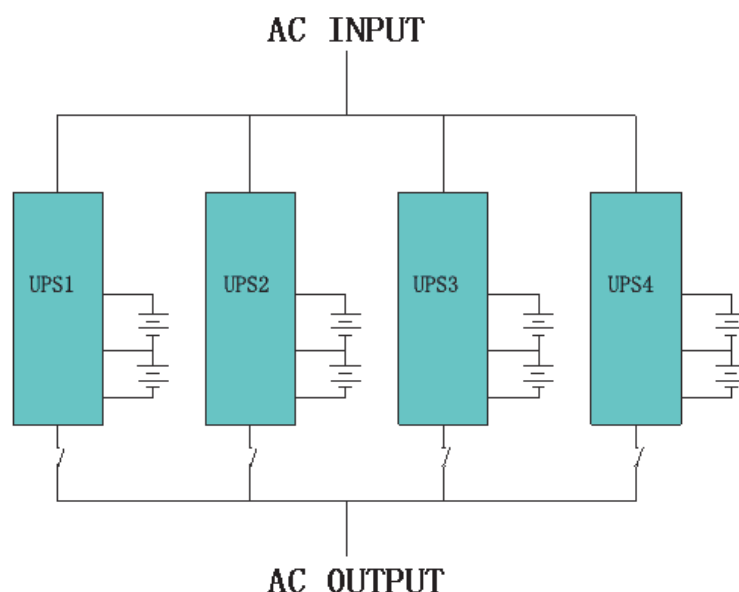

Make sure each UPS input switch is in “off” position and there is no any output from each UPS connected. Battery groups can be connected separately or in parallel, which means the system itself provides both separate battery and common battery.



## CAUTION!

A group of parallel systems is equivalent to a large capacity UPS, but it has higher reliability. In order to ensure that all UPS machines are current sharing, and comply with the relevant wiring rules, the following requirements should be met:

- ◆ All UPS must be the same rated and connected to the same way bypass power supply.
- ◆ Bypass and the mains input power must be received with the same neutral.
- ◆ The output of all UPS machines must be connected to a common output bus.
- ◆ All bypass input cables and UPS output cables should be of the same length and specification, which is to make the machine operate in the bypass mode and compare the current sharing.

### 3.8.2 Parallel cable installation

Shielded and double insulated control cables available must be interconnected in a ring configuration between UPS as shown below. The parallel control board is mounted on each UPS. The ring configuration ensures high reliability of the control.

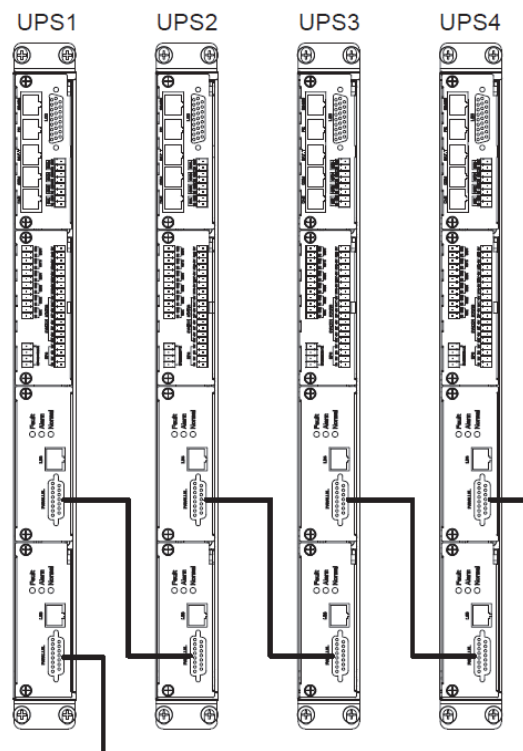

### 3.9 LBS installation (optional)

LBS system contains LCD set, cable connect and STS device.

#### 3.9.1 LCD setting

Set every UPS of the systems to be LBS Master or LBS Slave. For instance if the UPS belongs to LBS master system, its LBS setting must be set to Master.

#### 3.9.2 LBS cable installation

The two ports of one mesh wire should be plug into RJ45 interface of any one UPS of both master and slave system.

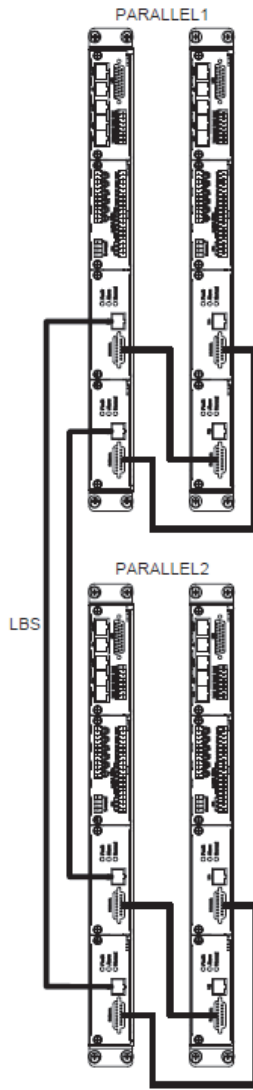

### 3.9.3 UPS installation

The whole systems are showed below.

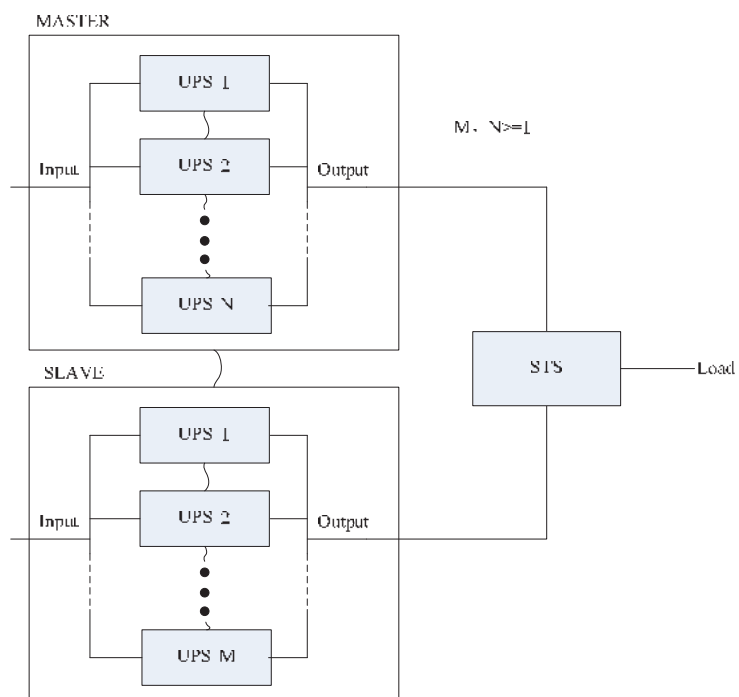

# 4. Operation

## 4.1 Operation Modes

The UPS is a double-conversion on-line UPS that may operate in the following alternative modes:

### ◆ Normal mode

The rectifier/charger derives power from the AC Mains and supplies DC power to the inverter while floating and boosting charge the battery simultaneously. Then, the inverter converts the DC power to AC and supplies to the load.

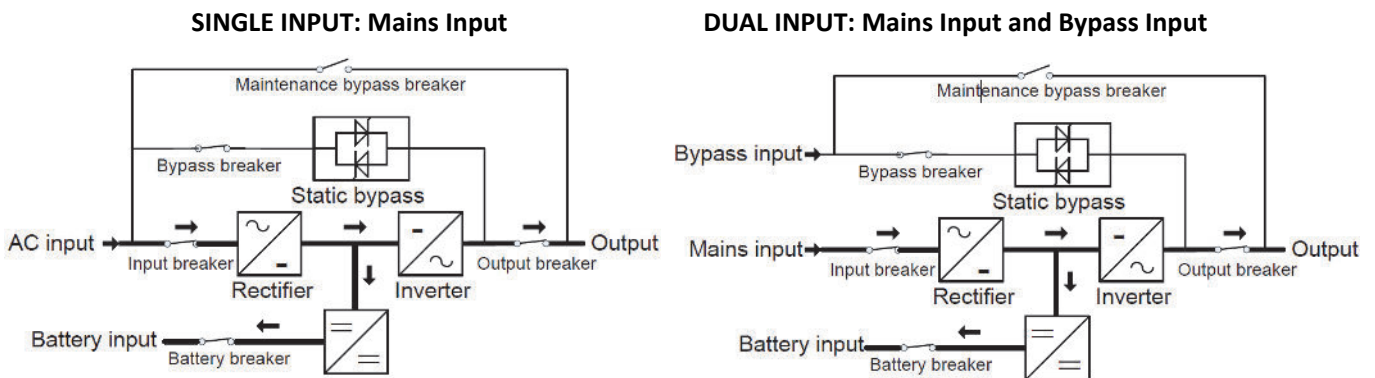

### ◆ Battery mode (Stored Energy Mode)

If the AC mains input power fails, the inverter, which obtains power from the battery, supplies the critical AC load. There is no power interruption to the critical load. The UPS will automatically return to Normal Mode when AC recovers.

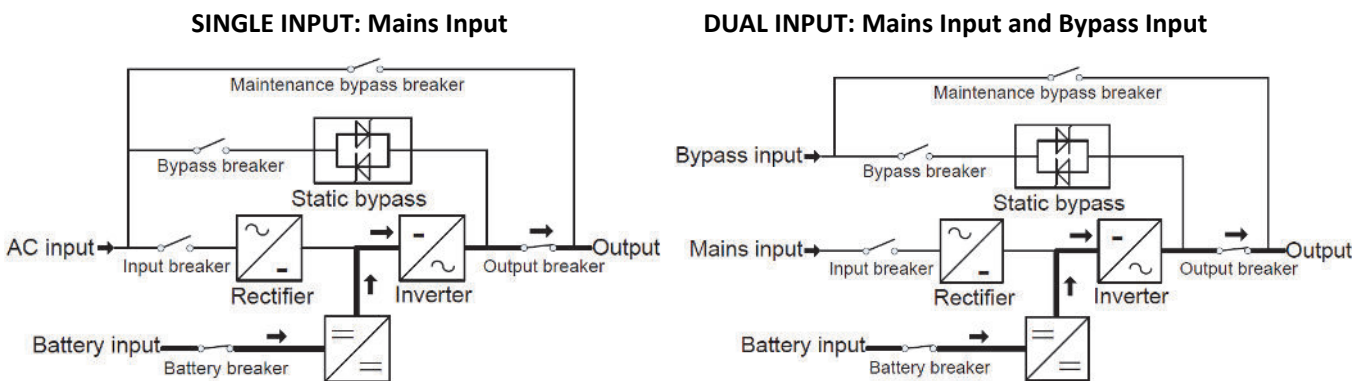

### ◆ Bypass mode

If the inverter is out of order, or if overload occurs, the static transfer switch will be activated to transfer the load from the inverter supply to bypass supply without interruption to the critical load. In the event that the inverter output is not synchronized with the bypass AC source, the static switch will perform a transfer of the load from the inverter to the bypass with power interruption to the critical AC load. This is to avoid paralleling of unsynchronized AC sources. This interruption is programmable but typically set to be less than an electrical cycle e.g. less than 15ms (50Hz) or less than 13.33ms (60Hz).

**SINGLE INPUT: Mains Input**

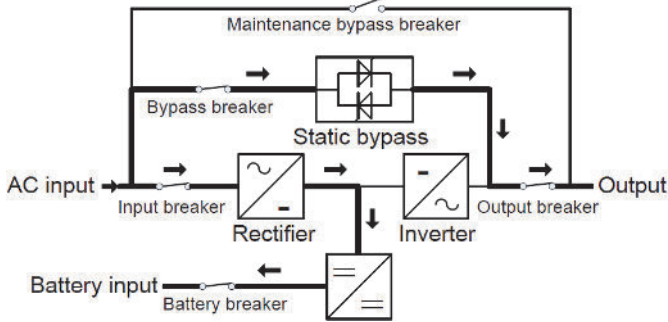

**DUAL INPUT: Mains Input and Bypass Input**

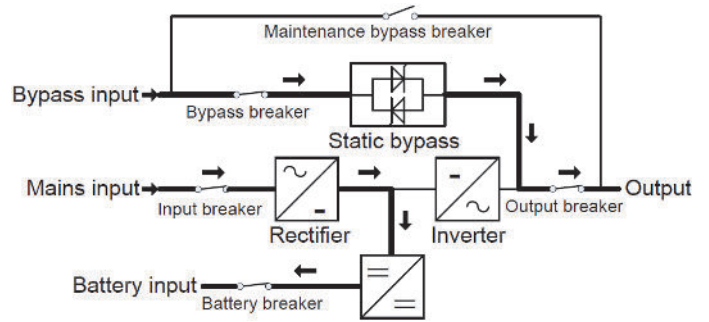

◆ **ECO Mode**

When the UPS is at AC Mode and the requirement to the load is not critical, the UPS can be set at ECO mode in order to increase the efficiency of the power supplied. At ECO mode, the UPS works at Line-interactive mode, so the UPS will transfer to bypass supply. When the AC is out of set window, the UPS will transfer from bypass to Inverter and supplies power from the battery, and then the LCD shows all related information on the screen.

**SINGLE INPUT: Mains Input**

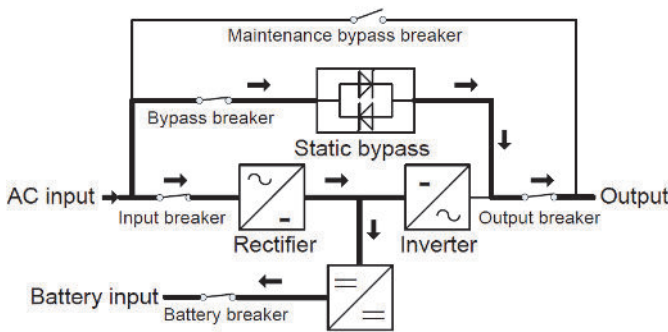

**DUAL INPUT: Mains Input and Bypass Input**

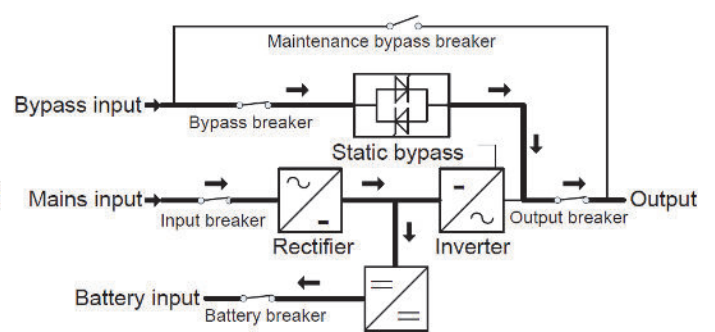

◆ **Maintenance mode (Manual Bypass)**

A manual bypass switch is available to ensure continuity of supply to the critical load when the UPS is out of order or in repair and this manual bypass switch bears for equivalent rated load.

**SINGLE INPUT: Mains Input**

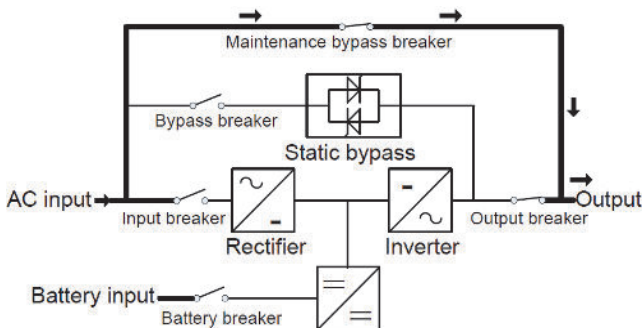

**DUAL INPUT: Mains Input and Bypass Input**

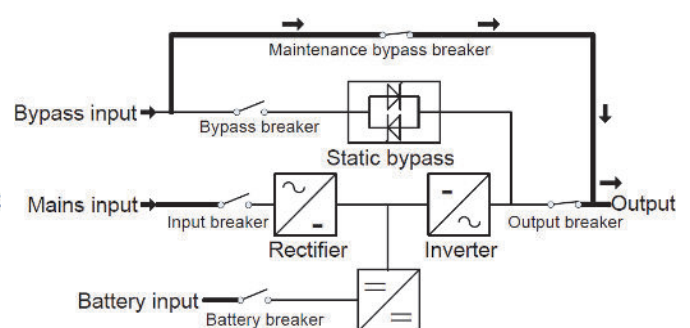

## 4.2 Turn on/off UPS

### 4.2.1 Restart procedure



#### CAUTION!

MAKE SURE GROUNDING IS PROPERLY DONE!

- ◆ Set the Battery Switch to the “ON” position according to the user’s manual.
- ◆ Open the front and rear doors of the UPS to access to the main power switches.

During this procedure the output terminals will become alive.



#### CAUTION!

Check to see if the load is safely connected with the output of the UPS. If the load is not ready to receive power from the UPS, make sure that it is safely isolated from the UPS output terminals

- ◆ Turn ON the bypass and input switches of the UPS, make sure that “Bypass module” insert the cabinet and fix with screws and the module\_in switch at the on status

When AC MAINS input voltage within the range, and the rectifiers of the UPS will be started up in 30 seconds, then the inverter is started completely. When the output switch is “ON”, the inverter LED lights up.

- ◆ Switch ON output switch

If the rectifier of the UPS does not start-up, the green LED will flash, bypass module green LED will light on, the power module green LED will flash. When UPS turn to inverter mode power module and display panel green LED will light on.

No matter the UPS is operated normally or not, the LCD display will indicate current status.

### 4.2.2 Test procedure



#### CAUTION!

The UPS is operating normally.

It may take 60 seconds to boost up the system and perform self-test completely.

- ◆ Switch off the MAINS to simulate utility failure, the rectifier will turn off and the battery should feed the inverter without interruption.
- ◆ Switch on the MAINS to simulate utility recovery, the rectifier will restart automatically after 20 seconds and the inverter will supply to the load. It is suggested to use Dummy loads for testing. The UPS can be loaded up to its maximum capacity during load test.

### 4.2.3 Cold start procedure



#### CAUTION!

Follow these procedures when the input AC Utility Failure, but battery is normal

- ◆ Switch on the battery switch.

The battery will feed the Auxiliary power board.

- ◆ Switch on the Output switch

- ◆ Trigger the cold start button of the bypass module.

When battery normal, rectifier starts operation, 30s later, inverter starts and operates and the green LED will light on.

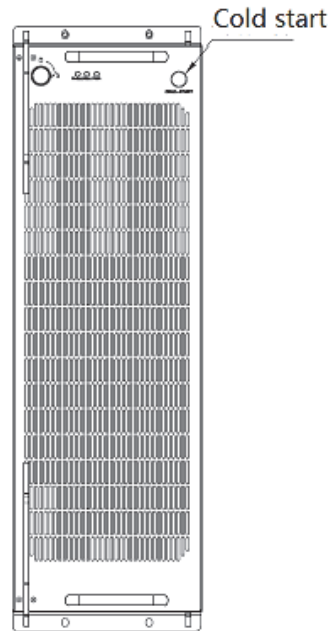

**CAUTION!**

Wait for approximately 30 seconds before you press the black start key

#### 4.2.4 MAINTENANCE BYPASS

To supply the load via Mains, you may simply active the internal mechanical bypass switch.



**CAUTION!**

The load is not protected by the UPS when the internal mechanical bypass system is active and the power is not conditioned.

#### Switch to mechanical bypass



**CAUTION!**

If the UPS is running normally and can be controlled through the display, carry out steps 1 to 5; otherwise, jump to Step 4.

- ◆ Open the cover of maintenance switch, the UPS turns to bypass mode automatically.
- ◆ Switch on MAINTANCE switch;
- ◆ Switch OFF BATTERY switch;
- ◆ Switch OFF the MAINS switch;
- ◆ Switch OFF OUTPUT switch;

At this time the bypass source will supply to the load through the MAINTENANCE switch.

#### Switch to normal operation (from mechanical bypass)



### **CAUTION!**

Never attempt to switch the UPS back to normal operation until you have verified that there are no internal UPS faults

- ◆ Open the front and rear doors of the UPS to be easily access to the main power switches
- ◆ Switch ON the output switch;
- ◆ Switch ON the input switch;
- ◆ Switch ON the battery switch;  
The UPS powers from the static bypass instead of the maintenance bypass.
- ◆ Switch OFF the maintenance bypass switch, then the output is supplied by the bypass of the modules.
- ◆ Put on the maintenance switch cover.

The rectifier will operate normally after 30 seconds. If the inverter works normally, the system will be transferred from bypass mode to normal mode.

#### **4.2.5 Shut down procedure**



### **CAUTION!**

This procedure should be followed to completely shut down the UPS and the LOAD. After all power switches, isolators and circuit breakers are opened, there will be no output.

- ◆ Press the INVERTER OFF key on the LCD display;
- ◆ Switch OFF the BATTERY switch;
- ◆ Open the UPS door to easily access to the main power switch;
- ◆ Switch OFF the input switch.
- ◆ Switch OFF the OUTPUT switch. The UPS shuts down;

### **WARNING!**



Wait for about 5 minutes for the internal D.C. bus bar capacitors to be completely discharged.

#### **4.2.6 Startup procedure for parallel system**

- ◆ Connect parallel cable, input/output cable, and battery cable well; modify the parallel board jumpers correctly.
- ◆ Measure the positive and negative battery pack voltage. Battery switch is opened temporarily.
- ◆ Switch ON the output switch at the front door.
- ◆ According to the startup procedure for single unit, set the operation mode of each UPS: single mode is changed to parallel mode; set the parallel number for each UPS; up to 4 units can be parallel; set the ID of each cabinet, the ID of each unit must be different.
- ◆ Switch ON the input switch. Close the external input switch and start from mains.

- ◆ After start from mains, check the LCD interface of each UPS to see if the ID, VA is the same with the actual values.
- ◆ Switch ON the external battery switch of each UPS. Check if the charging current displayed in LCD is normal.



**Note!**

The UPS cannot be parallel until each single unit is normal.

### 4.3 The Display

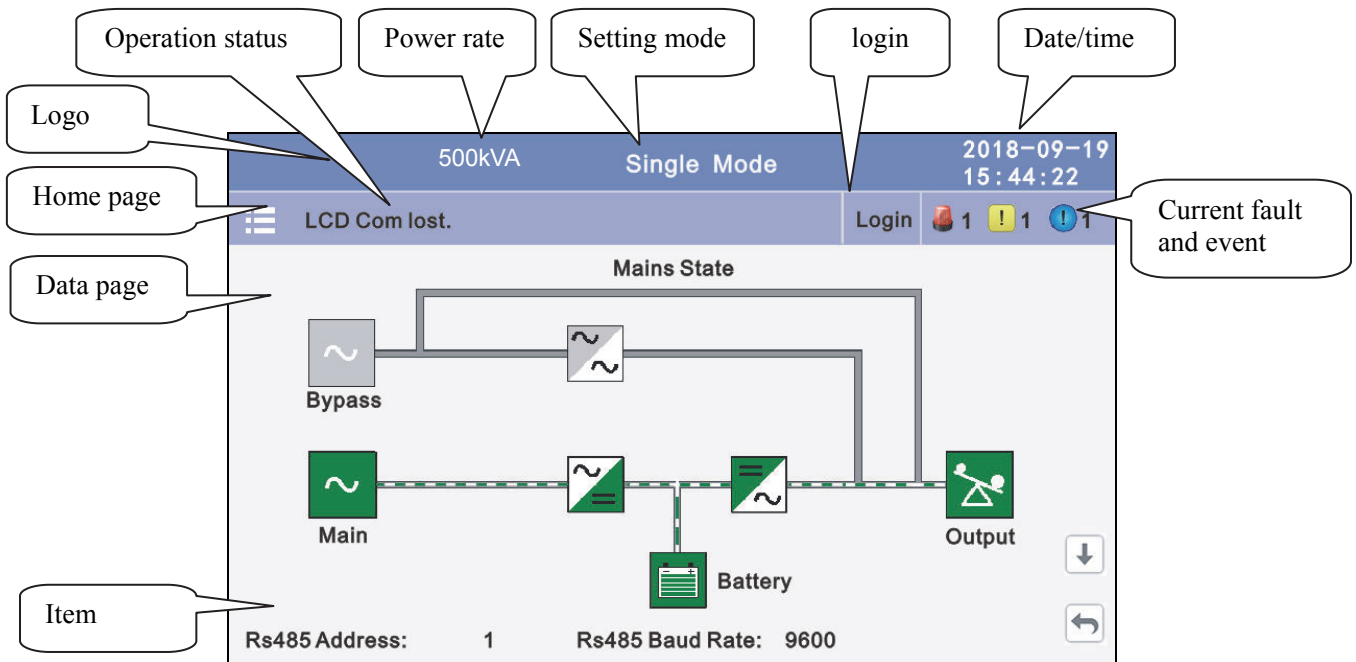

**4.3.1 Datas:** Displays the flow state of UPS work, and quickly enters real-time data by clicking on the block.

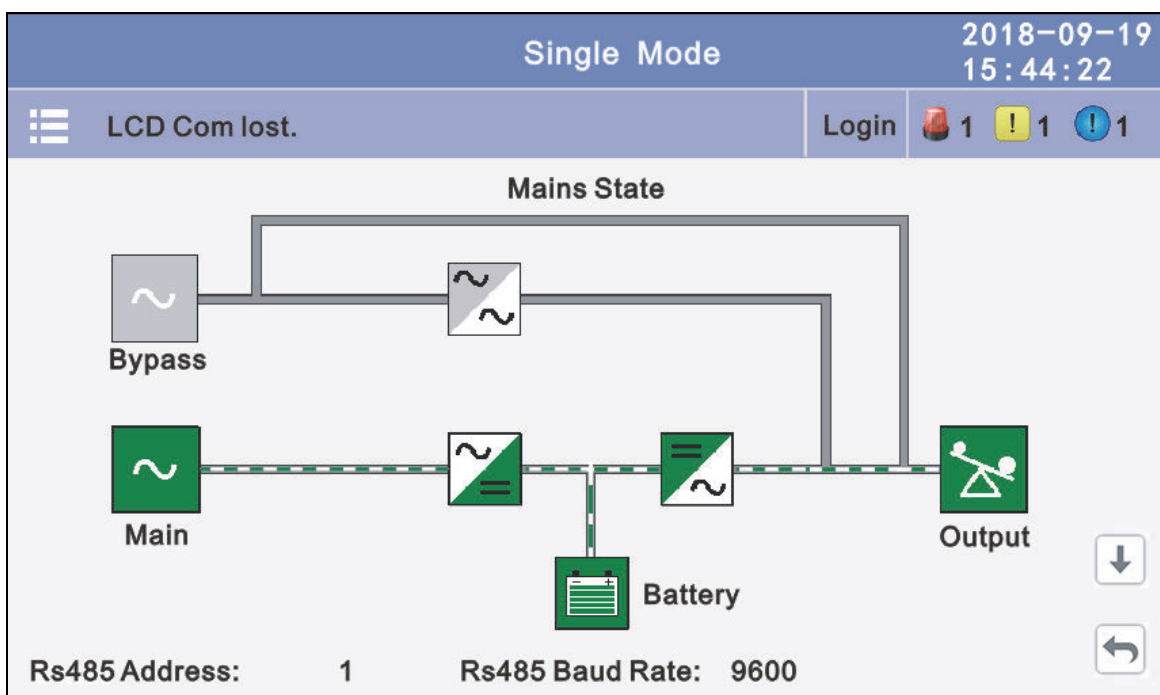

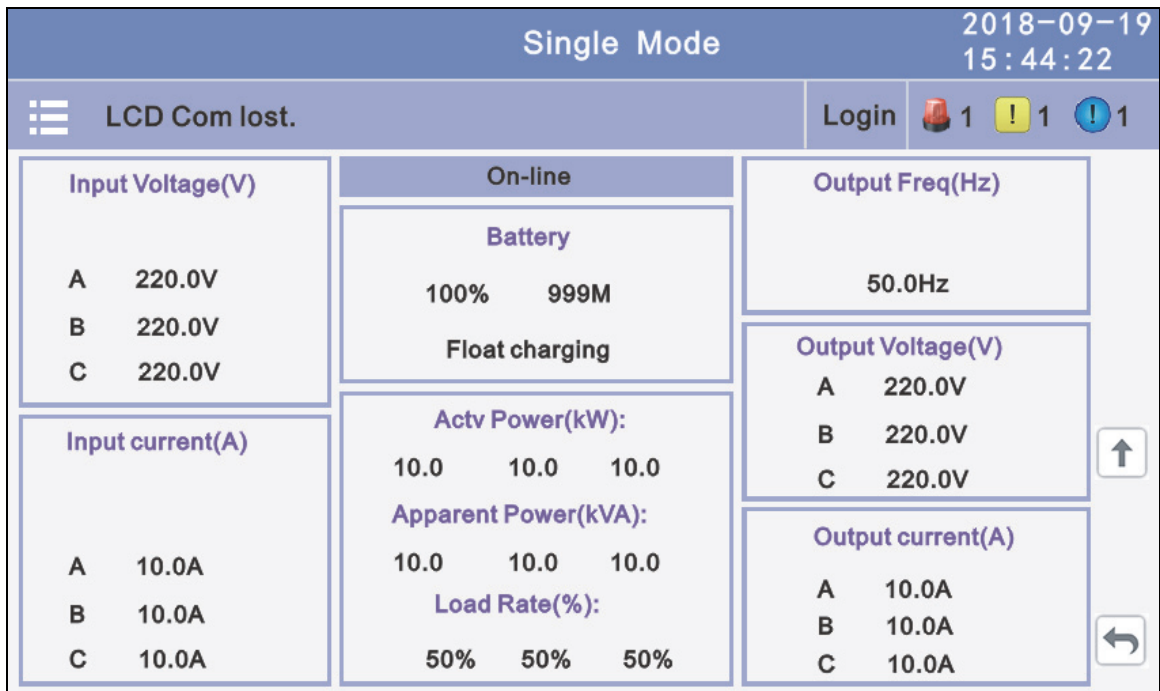

**4.3.2 Status:** View the voltage and current of the main, bypass, output, battery (can also be entered through by real-time data block), view the status of the switches, dry contacts, through clicking on the block, enter the corresponding data window.

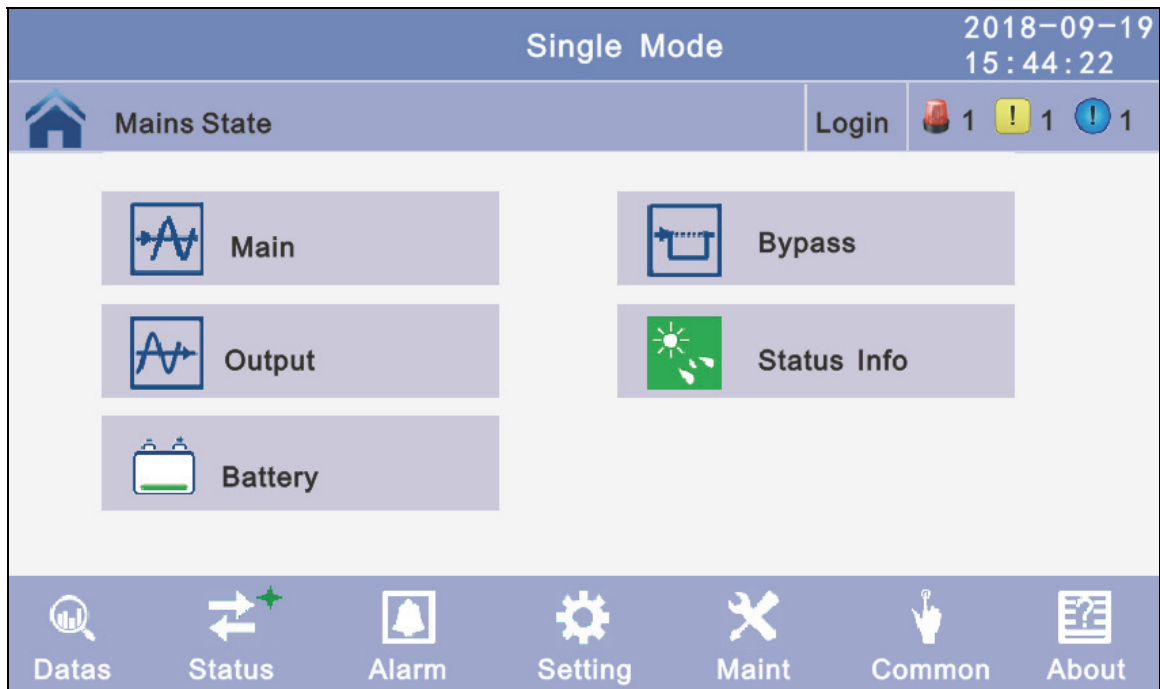

**4.3.2.1 Main:** Click the main block to enter the main data display window, click return to return to the previous window, click home page to return to the main page.

The screenshot shows a web interface titled 'Single Mode' with a date and time of '2018-09-19 15:44:22'. The page is divided into a header 'Mains State' with a 'Login' button and three status indicators (1 red, 1 yellow, 1 blue). The main content area features a green square icon with a white sine wave labeled 'Main'. To the right is a table with three columns (A, B, C) and five rows of electrical data.

	A	B	C
Phase Volt (V) :	220.0	220.0	220.0
Line Volt (V) :	380.0	380.0	380.0
Phase Freq (Hz) :	50.0	50.0	50.0
Phase Current (A) :	5.5	5.0	6.0
Input Factor:	0.932	0.931	0.921

**4.3.2.2 Bypass:** Click the bypass block to enter the bypass data display window, click return to return to the previous window, click home page to return to the main page.

The screenshot shows a web interface titled 'Single Mode' with a date and time of '2018-09-19 15:44:22'. The page is divided into a header 'Mains State' with a 'Login' button and three status indicators (1 red, 1 yellow, 1 blue). The main content area features a green square icon with a white sine wave labeled 'Bypass'. To the right is a table with three columns (A, B, C) and three rows of electrical data.

	A	B	C
Phase Volt (V) :	220.0	220.0	220.0
Line Volt (V) :	380.0	380.0	380.0
Phase Freq (Hz) :	50.0	50.0	50.0

**4.3.2.3 Output:** Click the output block to enter the output data display window, click return to return to the previous window, click home page to return to the main page.

Single Mode 2018-09-19  
15:44:22

Mains State Login 1 1 1

	A	B	C
Phase Volt (V) :	220.0	220.0	220.0
Line Volt (V) :	380.0	380.0	380.0
Phase Freq (Hz) :	50.0	50.0	50.0
Phase Current (A) :	5.5	5.0	6.0

Output

Single Mode 2018-09-19  
15:44:22

Mains State Login 1 1 1

	A	B	C
Apparent Power (kVA) :	1.0	1.0	1.0
Actv Power (kW) :	1.0	1.0	1.0
Load Rate (%) :	1.0%	1.0%	1.0%
Load Peak Ratio:	1.5	1.0	1.0

Output

**4.3.2.4 Battery:** Click the battery block to enter the battery data display window, click return to return to the previous window, click home page to return to the main page.

Single Mode 2018-09-19 15:44:22

Mains State Login 🔴 1 🟡 1 🔵 1

<b>Voltage (V) :</b>	+240	-240
<b>Current (A) :</b>	+10	-10
<b>Batt Status:</b>	Boost	Boost
<b>Temp (°C) :</b>	0.0	

↓ ↶

Single Mode 2018-09-19 15:44:22

Mains State Login 🔴 1 🟡 1 🔵 1

<b>Cap Rate (%) :</b>	100
<b>Backup Time (min) :</b>	100
<b>Discharge Time (min) :</b>	100

↑ ↶

**4.3.2.5 Status info:** Click the status info block to enter the status data display window, click return to return to the previous window, click home page to return to the main page.

The screenshot shows a web interface titled "Single Mode" with a date and time of "2018-09-19 15:44:22". The main header includes a home icon, "Mains State", a "Login" button, and three notification icons (red bell, yellow exclamation mark, blue exclamation mark), each with a "1". On the left, there is a green square icon with a sun and raindrops, labeled "Status Info". The main content area displays two rows of data:

Output Switch	Open
MBS Switch	Open

At the bottom right, there are two buttons: a downward arrow and a return arrow.

The screenshot shows the same "Single Mode" interface. The main header and notification icons are identical. The "Status Info" icon is present on the left. The main content area displays four rows of data:

Dry Battery Switch	Open
Dry Output Switch	Open
Dry Bypass Switch	Open
Dry Maint Bypass Switch	Open

At the bottom right, there are two buttons: a downward arrow and a return arrow.



**4.3.3 Alarm:** View the alarm and history of the UPS, and open or close the buzzer.



**4.3.3.1 Curr Alarm:** Click the curr alarm to enter the current alarm display window, click return to return to the previous window, click home page to return to the main page.

No.	Level	Info	Loc
001	!	14C-01 ECU Abnormal	ECU 01
002	!	09C-01 Dry Node Comm. Fault	ECU 01

**4.3.3.2 History:** Click the history to enter the history recode display window, click return to return to the previous window, click home page to return to the main page.

No.	Level	Info	Loc	Time
0001	!	On Line	System	2018-06-15 18:12:00
0002	!	Rectifier Activated	System	2018-06-15 18:12:00

**4.3.3.3 Buzzer:** Click the buzzer mute then the buzzer will mute and the red block will change to green, if the buzzer is on, then click the block buzzer will on and the block will change to red. click return to return to the previous window, click home page to return to the main page.

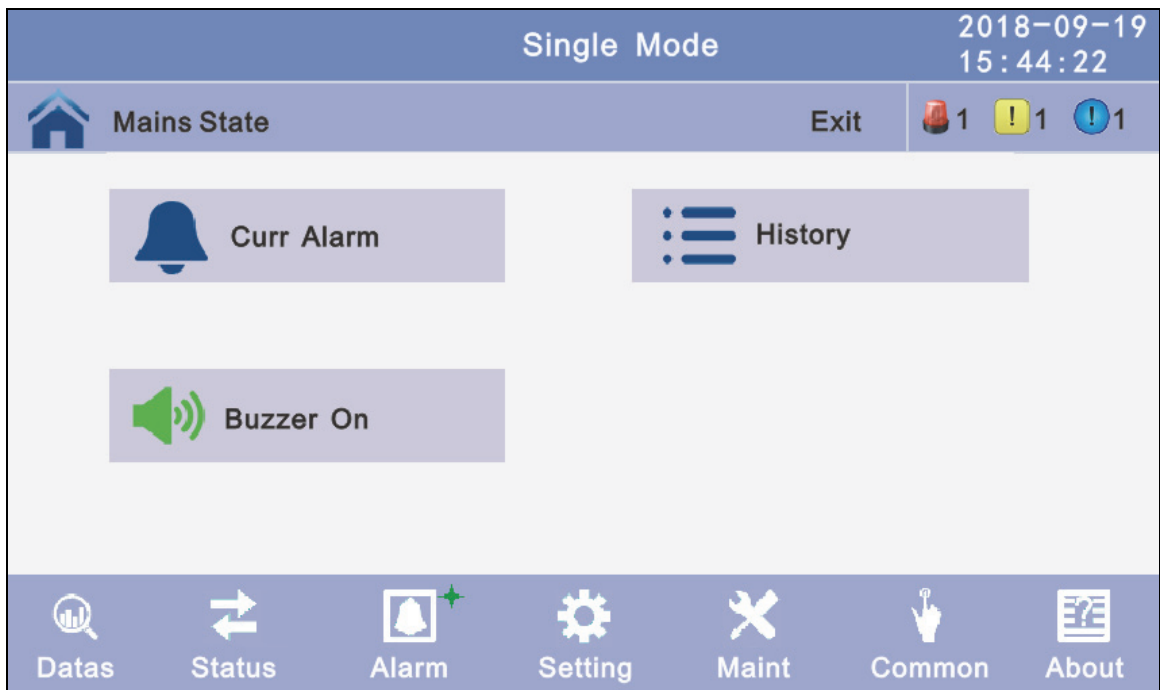

**4.3.4 Setting:** There are two levels, the basic setting for user settings, advanced setting for technical personnel, please contact the relevant technical personnel to enter advanced settings.

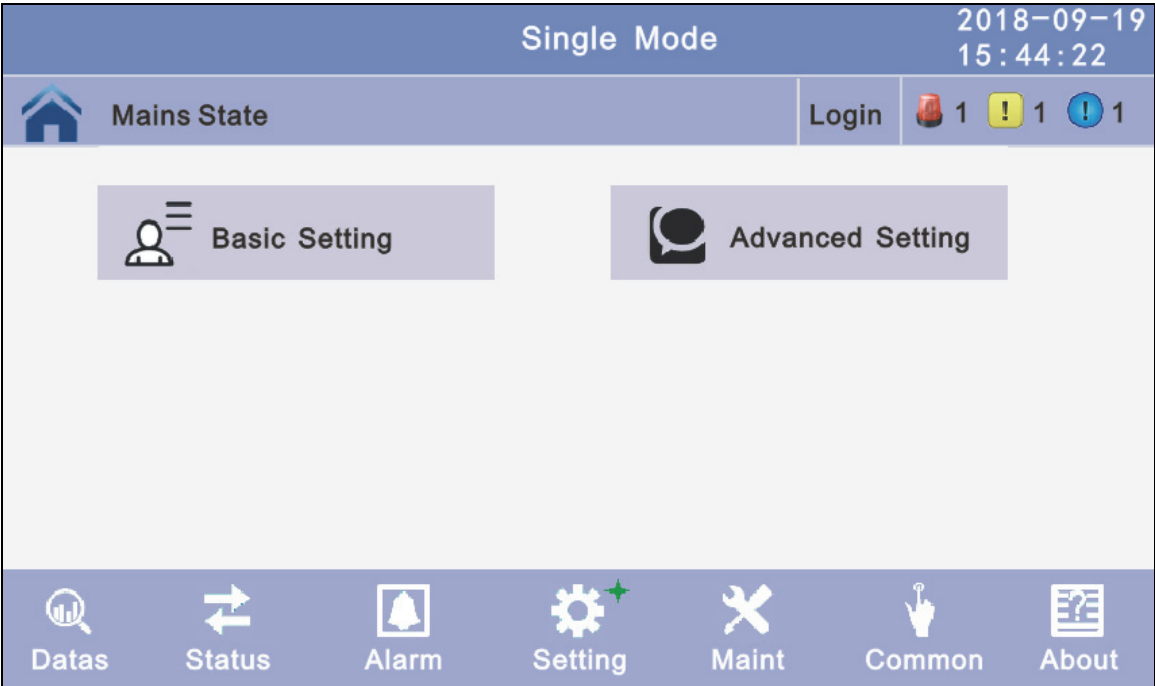

**4.3.4.1 Basic Setting:** Click basic setting, enter by input the correct password. The user password is "111111".

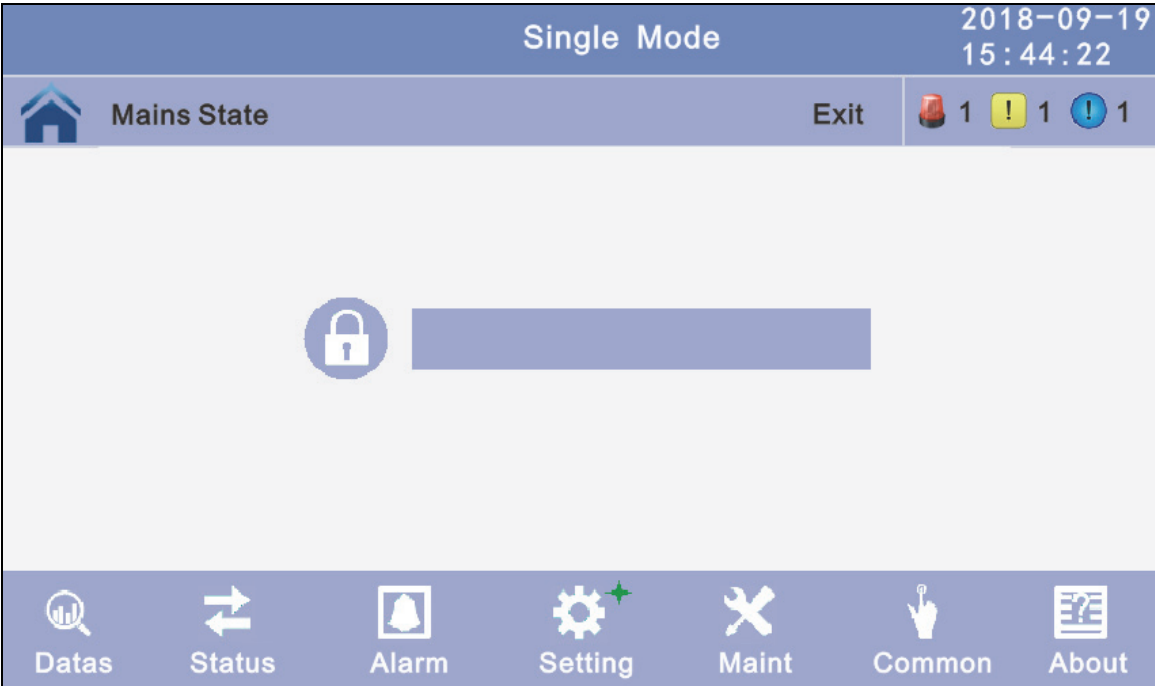

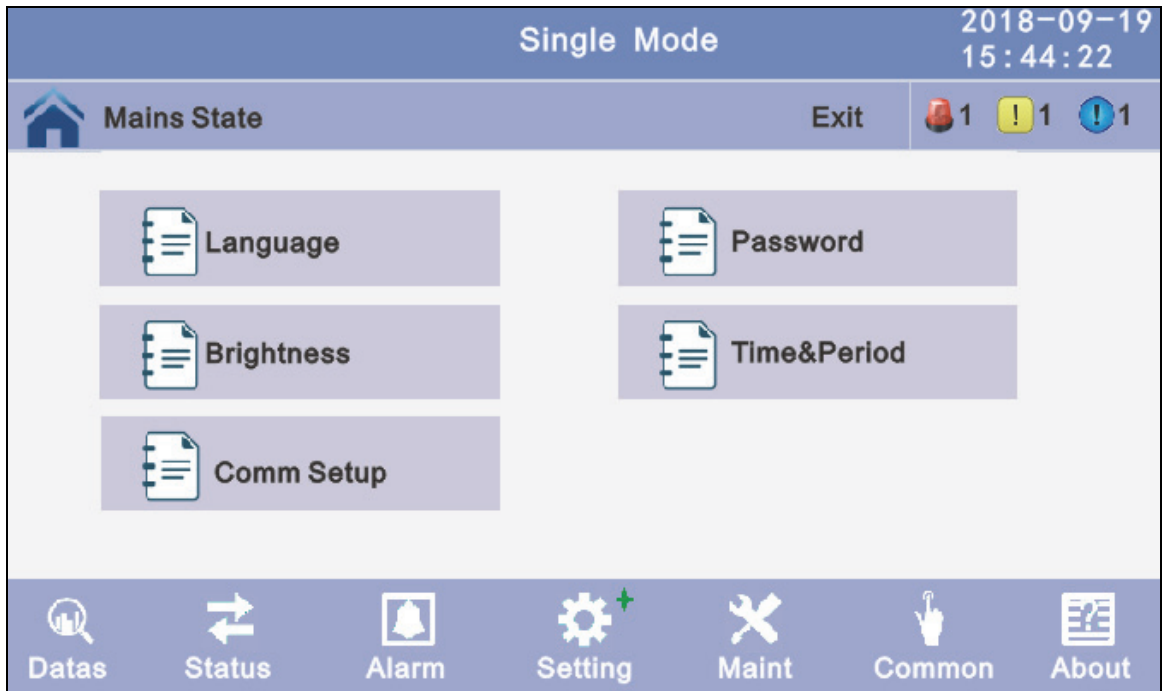
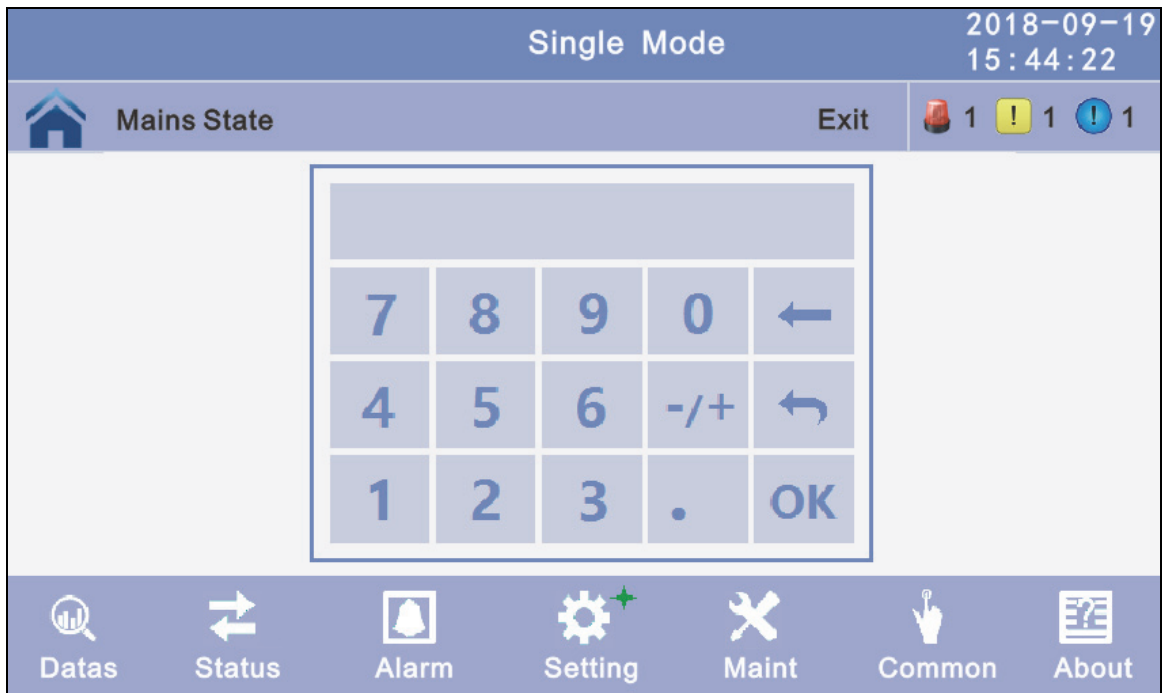

**4.3.4.1.1 Language:** Click the language block witch you want and click the save config block to save. click return to return to the previous window, click home page to return to the main page.



**4.3.4.1.2 Password:** Click password block enter user password setting page, input old password and new password, then click save confir to save the change. Password format is six number. click return to return to the previous window, click home page to return to the main page.

**Password lock time:** When LCD is not touched, it needs to re login when the setting value is set, click left or right block to change the value.

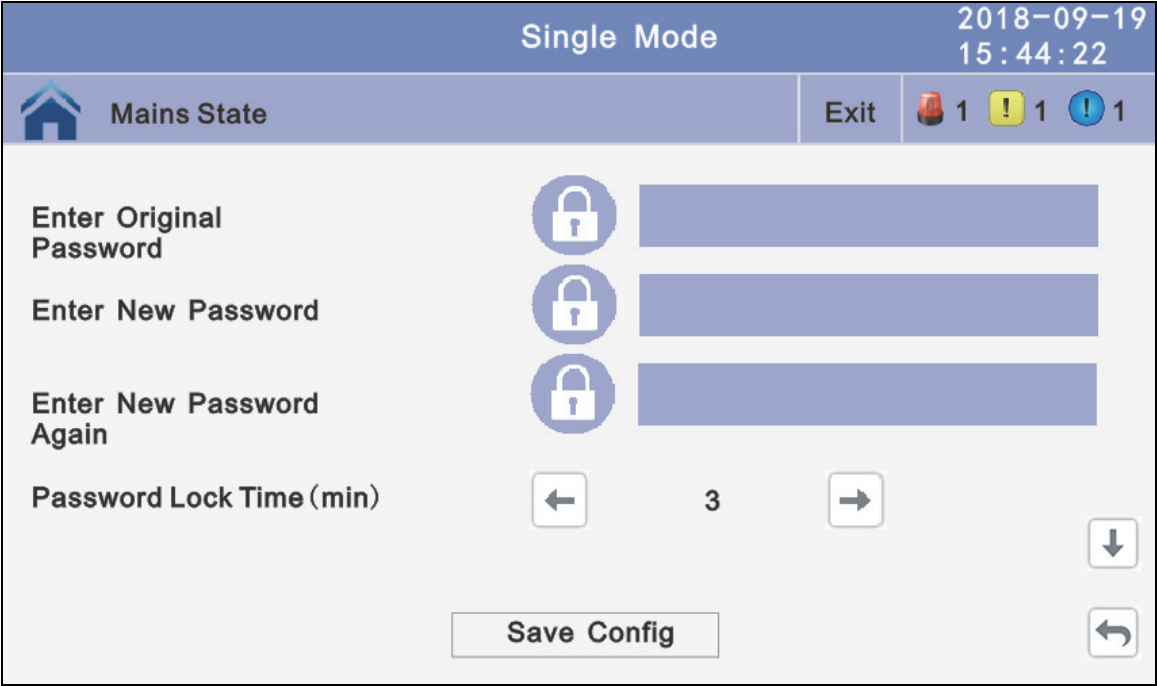

**4.3.4.1.3 BrighNess and Backlight time:** Click the block to change value. click return to return to the previous window, click home page to return to the main page.

**BrighNess:** Click the text to input new value and click the save config block to save. Value range is 1~63, default value is 63. Click return to return to the previous window, click home page to return to the main page.

**Backlight time:** LCD backlight delay time, click the text to input new value and click save config block to save. Value range is 1~255, default value is 60. Click return to return to the previous window, click home page to return to the main page.

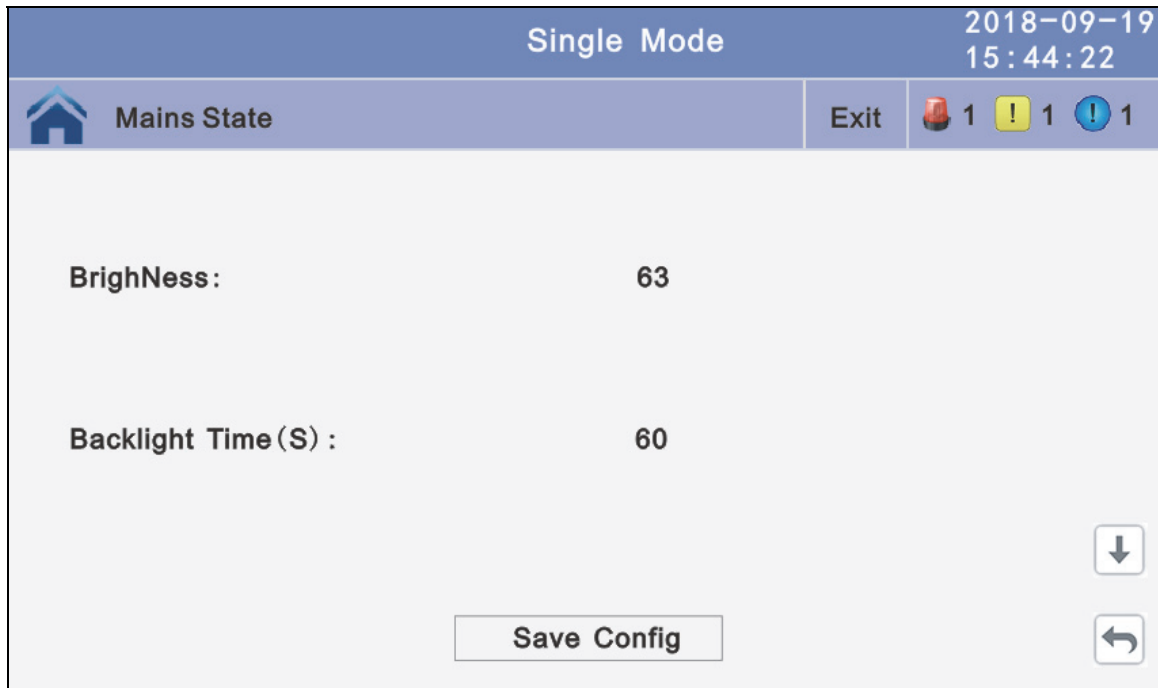

**4.3.4.1.4 Date and time setting:** Click the text to select other value or input new value and click save config block to save. Click return to return to the previous window, click home page to return to the main page.

**Date:** current date

**Time:** current time



**4.3.4.1.5 Communication setting:** Click the text to select other value or input new value and click save config block to save. Click return to return to the previous window, click home page to return to the main page.

**Rs485 address:** UPS communication ID, address range is 1~15, default is 1

**Rs485 Baud Rate:** baud rate: 2400, 4800, 9600, 14400, 19200, default is 9600



**4.3.4.2 Advanced Setting:** Click advanced setting, enter by input the correct password. The user password is "191210".

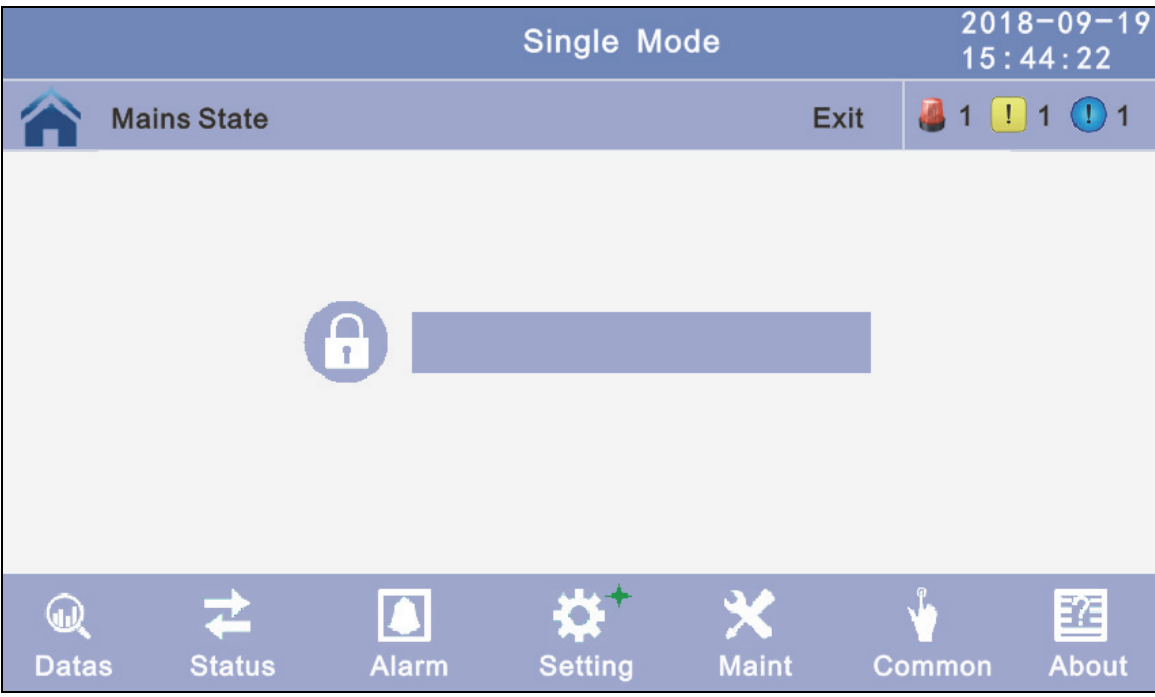

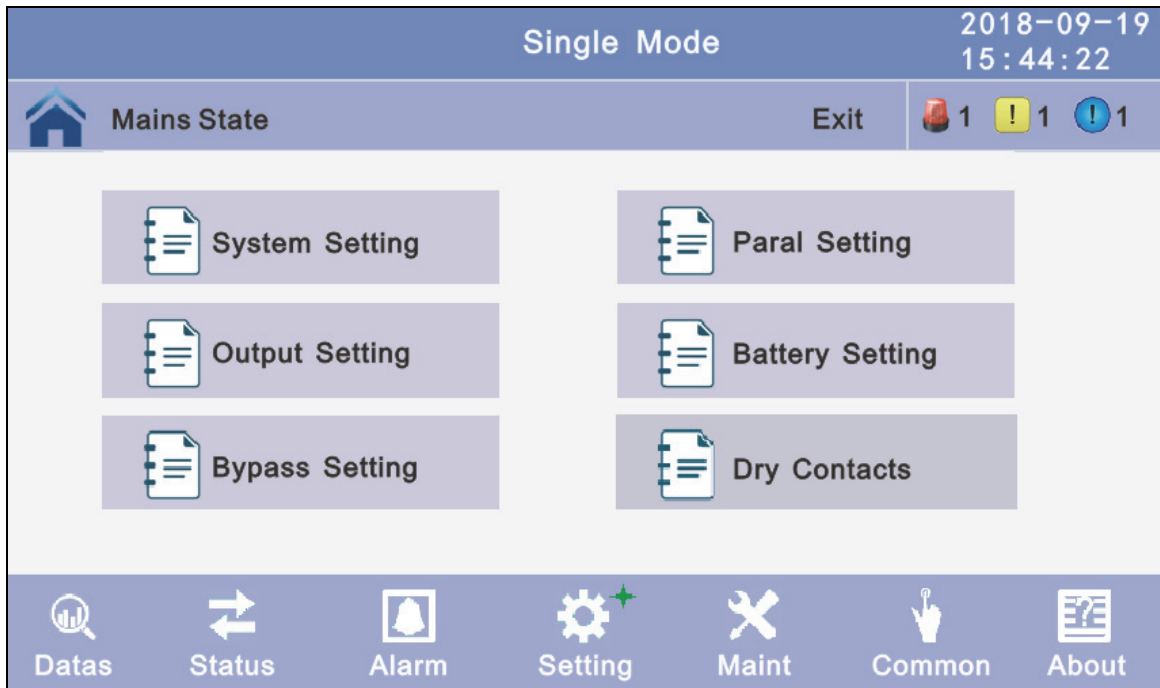
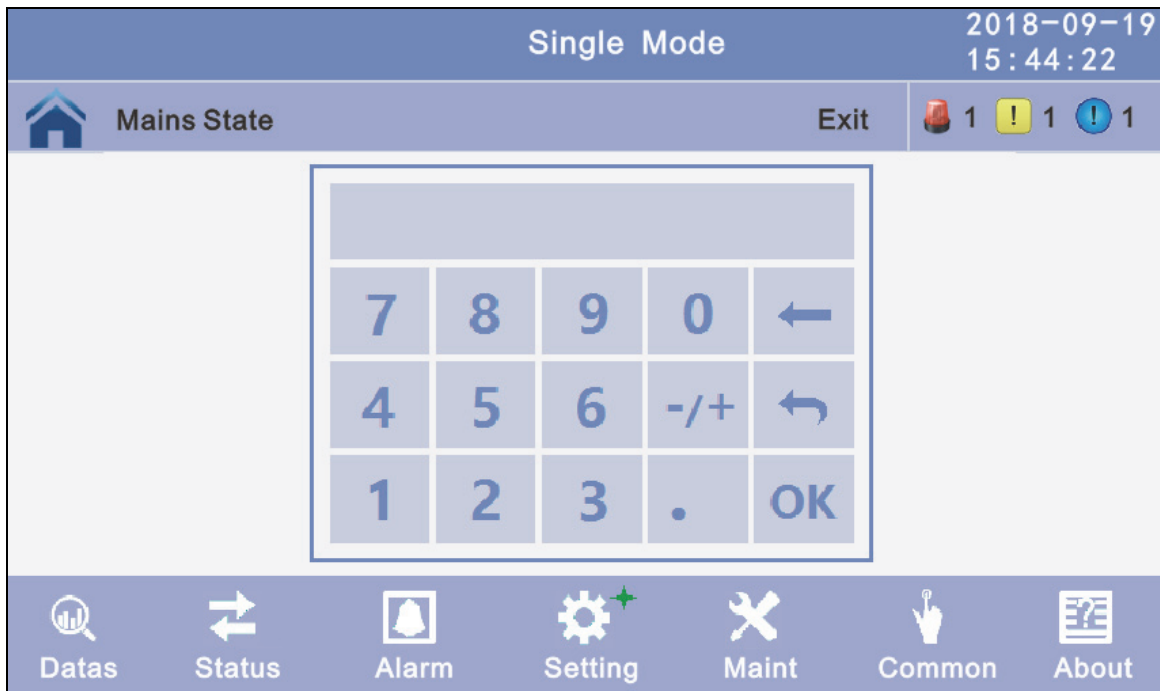

**4.3.4.2.1 System setting:** Click the text to select other value or input new value and click save config block to save. Click return to return to the previous window, click home page to return to the main page.

**Working Mode:** Select the work mode of UPS, work mode:Single mode, Parallel mode, ECO mode.

**Auto Turn-on:** Select the UPS start logic, Enable:UPS start inverter output automatic, Disable: No output.

**Aging Load Rate:** The value can be 18~100%, default value: 60%



**Rreq Conv Mode:** Frequency conversion mode, enable: output frequency set 50Hz or 60Hz, input frequency is 60Hz or 50Hz, UPS no alarm not battery and bypass abnormal. Default is Disbale.

**LBS mode:** setting value: LBS disable, LBS master, LBS slave. Default is LBS disable.

**Temp Sensor Switch:** temperature sensor compensation switch, when need to connectbattery temperature sensor, please chage the value to enable.

**Temp Sensor Select:** temperature sensor type select. Has tow types: NTC and RS485. NTC for single and short distance. Rs485 for multiple and far distance.

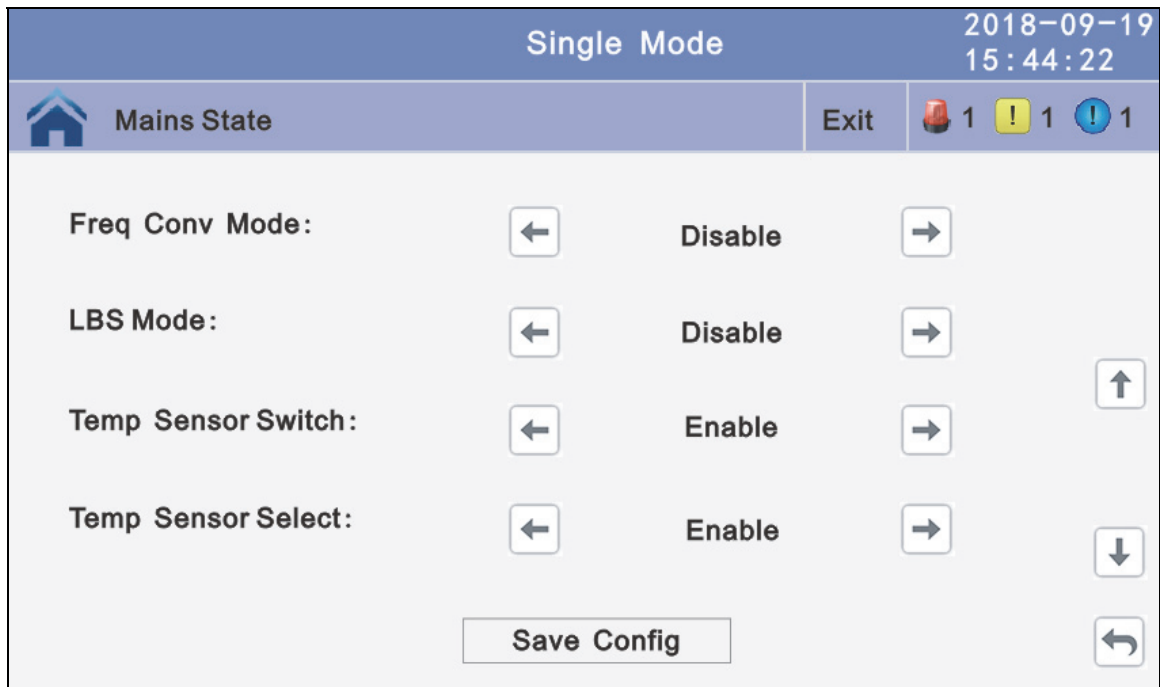

**Inter Power Walk in:** this is enable the UPS to control the interval that each rack transfers from battery mode to normal mode, which reduces the impact on the generator or power grid. The value can be 0~200, default value is 10.

**Inter sleep mode:** when load less than the software setting value, same parallel rack will turn to standby mode and if the load more than the setting value some rack will turn to inverter mode after setting the sleep mode enable. Default value is disable.



**Paral Operation ID:** Parallel operation ID, must modify the ID after set work mode to parallel mode. The value can be 1~6, default value is 1.

**Cabinet Paral Basic Units:** Parallel cabinet number, must modify the total parallel cabinet number after set work mode to parallel mode. The value can be 2~6, default value is 2.

**Cabinet Paral Redunt Units:** Parallel redundancy cabinet number, can modify the redundancy cabinet number after set work mode to parallel mode. The value can be 0~5, default value is 0.

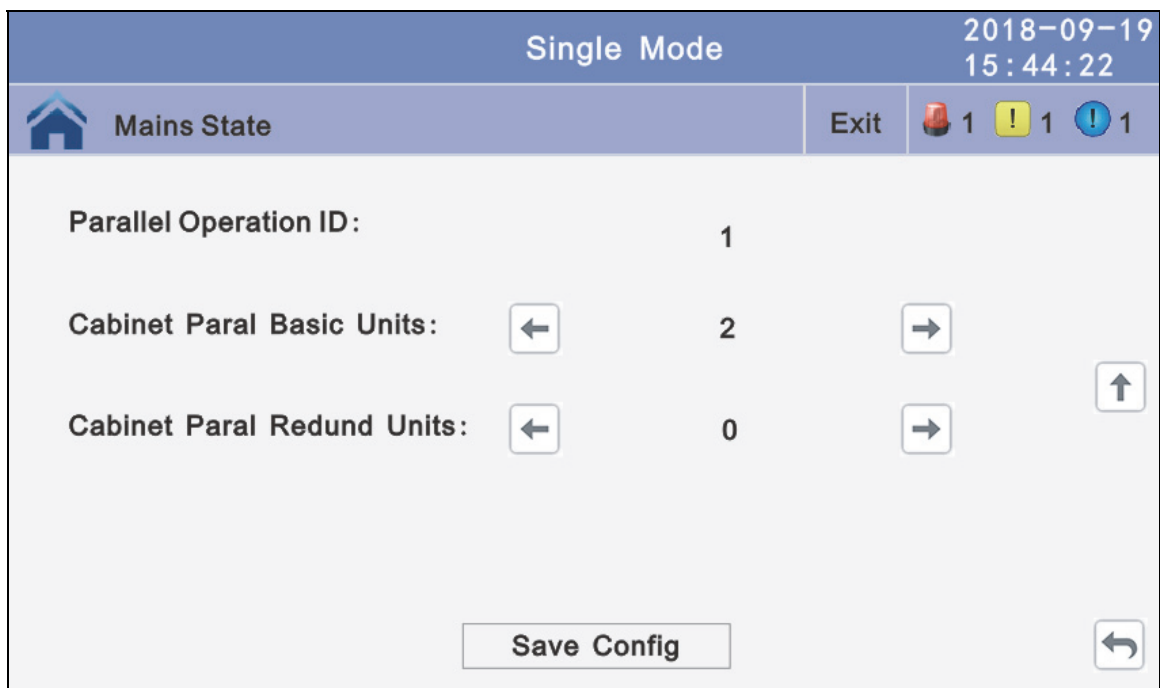

**Output Freq:** Output frequency, The value can be 50Hz or 60Hz.

**Output Volt Level:** Output voltage level, The value can be 220V, 230V, 240V.

**Output lvn Volt Regu:** Inverter voltage regulated, The value can be -5%~0~+5%, step is 0.5%, default value: 0.

The screenshot shows a configuration interface titled 'Single Mode' with a timestamp of 2018-09-19 15:44:22. The main menu includes 'Mains State', 'Exit', and three status indicators (red, yellow, blue) each with a '1'. The configuration items are: 'Output Freq (Hz) : 50.0', 'Output Volt Level (V) : 220.0', and 'Output lvn Volt Regu (%) : 0.0'. Each item has left and right arrow buttons for adjustment. At the bottom, there is a 'Save Config' button and a back arrow.

**Battery Group:** Must modify the numer to actual configuration, The value can be 1~8, default value is 1.

**Battery number:** Must modify the numer to actual configuration, The value can be 30~50, default value is 30.

**Single Battery Capability:** Must modify the value to actual configuration, The value can be 7~2000.

**Boost/Float conversion:** boost charge and float charge alternate time, The value can be 0~20.

The screenshot shows a configuration interface titled 'Single Mode' with a timestamp of 2018-09-19 15:44:22. The main menu includes 'Mains State', 'Exit', and three status indicators (red, yellow, blue) each with a '1'. The configuration items are: 'Battery Group: 1', 'Battery Number: 36', 'Single Battery Capability (AH) : 2000', and 'Boost/Float Conversion (Month) : 0'. The first three items have left and right arrow buttons for adjustment. The last item has a down arrow button. At the bottom, there is a 'Save Config' button and a back arrow.

**Chg.cur.limiting coef.:** The charging current limit is a multiple of the battery capacity. The value can be 0.05~0.15, and is 0.1 by default.

**Cell float voltage:** The float voltage value can be 2.23~2.30 V/cell, and is 2.25 V/cell by default.

**Cell boost voltage:** The battery equalized voltage value can be 2.30~2.40 V/cell, and is 2.30 V/cell by default.

**Aver charging Duration:** boost charge time limit, the value can be 1~999min , and is 240 by default.

Single Mode			2018-09-19 15:44:22		
Mains State	Exit	1	1	1	
Chg. cur. limiting coef. (0.01C) :		0.15			
Cell float voltage (V/Cell) :		2.25			
Cell boost voltage (V/Cell) :		2.40			
Aver Charging Duration (min) :		999			
<input type="button" value="Save Config"/>					

**EOD Battery Volt:** End of discharge voltage. The value can be 1.60~1.90, and is 1.80 by default.

**Float Temp Compens Coeff:** modify the voltage of compensation after enable the switch. the value can be 0.001~0.007/cell, and is 0.003 by default.

**Boost Charge Setting:** Boost charge disable or enable, and is enable by default.

**No Battery Warning:** can be no warning when no battery after set disable, and is enable by default.

Single Mode			2018-09-19 15:44:22		
Mains State	Exit	1	1	1	
EOD Battery Volt (V/Cell) :		1.80			
Float Temp Compens Coeff (V/Cell/°C) :		0.003			
Boost Charge Setting :		Enable			
No Battery Warning :		Enable			
<input type="button" value="Save Config"/>					

**Cabinet shared battery:** tow parallel ups use common batter bank. The value can be set share battery pack or Not shared battery P, not shared battery P by default.

**Generator on prohibit charging:** UPS disable charge the battery if set the value to enable when the generator signal is enable.

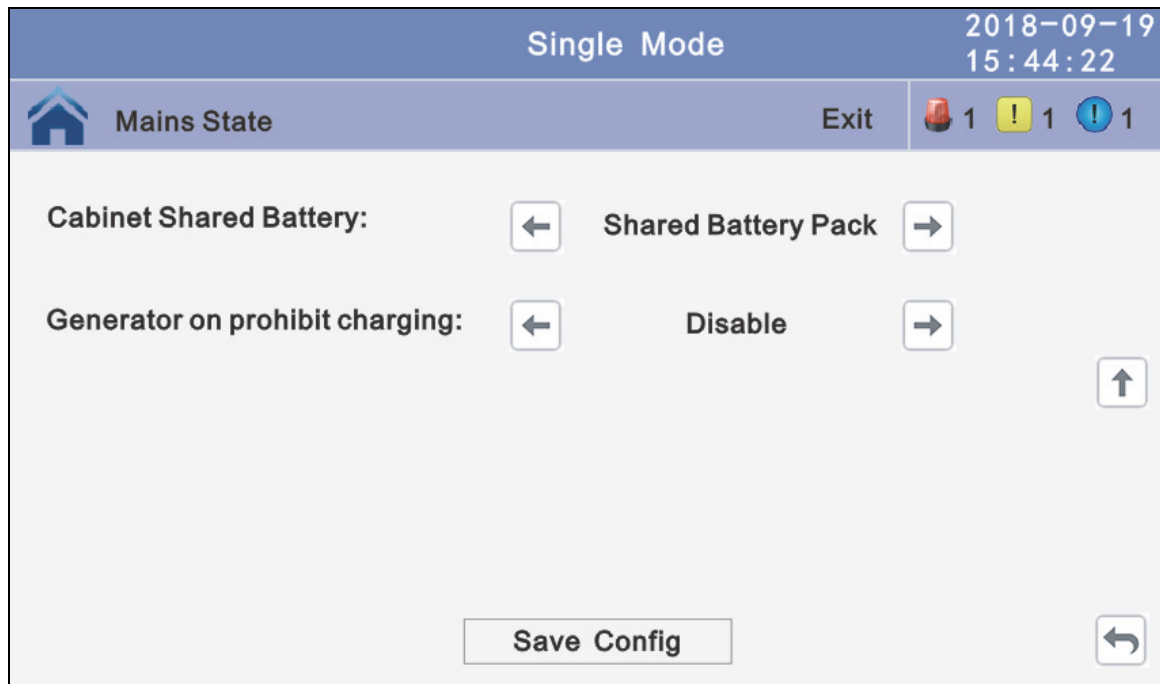

**Bypass Volt Prot Lower Limit:** When the difference between the bypass voltage and the rated voltage exceeds the lower threshold for the bypass voltage, the system determines that the bypass voltage is abnormal and that the bypass is unavailable. The value can be -10%, -15%, -20%, -30%, -45%,. The default value is -45%.

**Bypass Volt Prot Limit:** When the difference between the bypass voltage and the rated voltage exceeds the upper threshold for the bypass voltage, the system determines that the bypass voltage is not normal and that the bypass is unavailable.

NOTE:

When the voltage level is 380 V, the value range is 10%, 15%, 20%, and 25% (default).

When the voltage level is 400 V, the value range is 10%, 15%, and 20% (default).

When the voltage level is 415 V, the value range is 10% and 15%(default).

**Bypass Freq Tracking Range:** When the difference between the bypass input frequency and the rated frequency is greater than this value, the system determines that the bypass frequency is not normal, and that the bypass is unavailable. The value range is 1%, 2%, 4%, 5%, 10%(default).

**Bypass rate tracking rate:** Inverter frequency tracking to bypass frequency rate. The value range is 0.5~2, and is 1 by default.

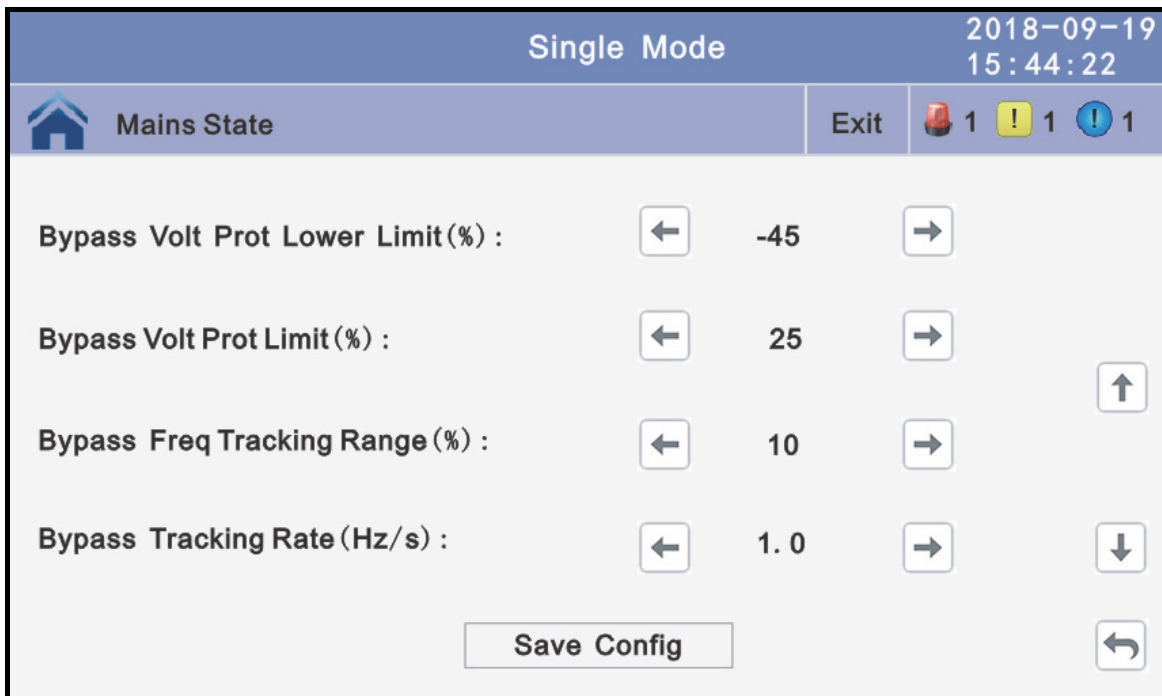

**Power Supply upon bypass Over Temp:** Specifies whether to start bypass mode when overtemperature occurs. The default value is Enable.

**Bypass Switches Limit:** Cross currents occur during the transfer between bypass mode and normal mode, which impacts the system. This parameter specifies the number of transfers between bypass mode and normal mode within 1 hour, which ensures system security. The value can be 3 to 10, and is 10 by default.

**EPO transfers to bypass:** Specifies whether to start bypass mode when EPO occurs. The default value is Enable.



**Battery abnormal BCB trip:** Enable or disable BCB trip single output. The default value is Disable.

**Bypass Feedback:** Enable or disable bypass feedback output. The default value is Disable.

**External Maint. breaker:** Enable or disable external maintenance breaker connection detection. The default value is Disable.

**Battery Switch:** Enable or disable battery breaker connection detection. The default value is Disable.

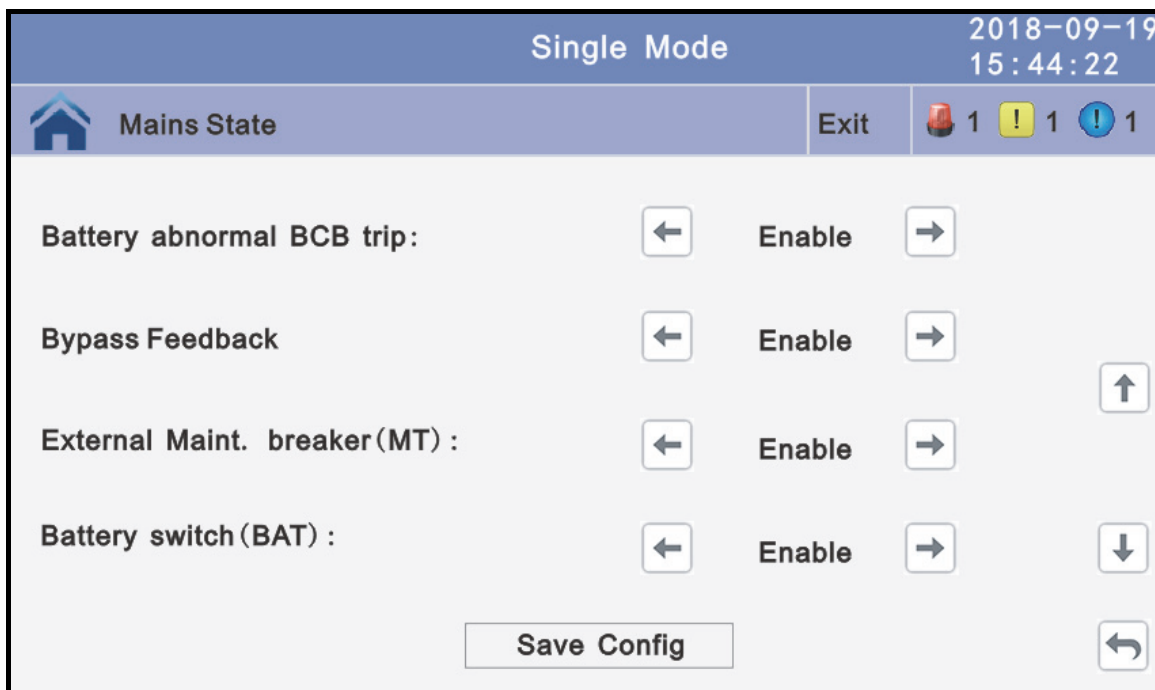

**Output Switch:** Enable or disable output breaker connection detection. The default value is Disable.

**Bypass Switch:** Enable or disable bypass breaker connection detection. The default value is Disable.

**Battery ground Fault:** Enable or disable battery grounding failure detection. The default value is Disable.

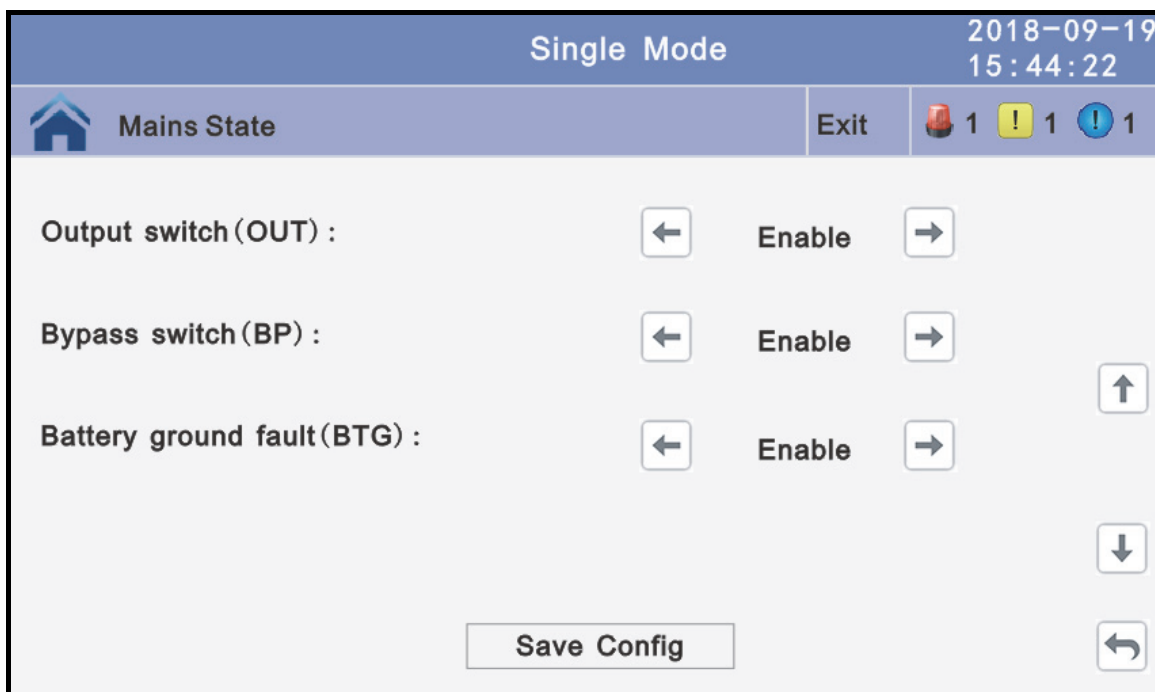

**Lightning arrester (SPD):** Enable or disable SPD detection. The default value is Disable.

**Generator (GEN):** Enable or disable GEN detection. The default value is Disable.



**OUT01~OUT06:** Output dry contact port, modify on the LCD. The default value is Disable.

Setting value:

No.	Item	No.	Item
1	URGENT_ALARM	7	BYPASS_SUPPLY
2	MINOR_ALARM	8	BATTERY_SUPPLY
3	MAIN_ABNORMAL	9	NO_SUPPLY
4	BATTERY_LOW_VOLT	10	ECO_MODE
5	BATTERY_SELFHECK	11	MAINT_CLOSE
6	MAIN_SUPPLY	12	OIL_MACHINE_CONTROL

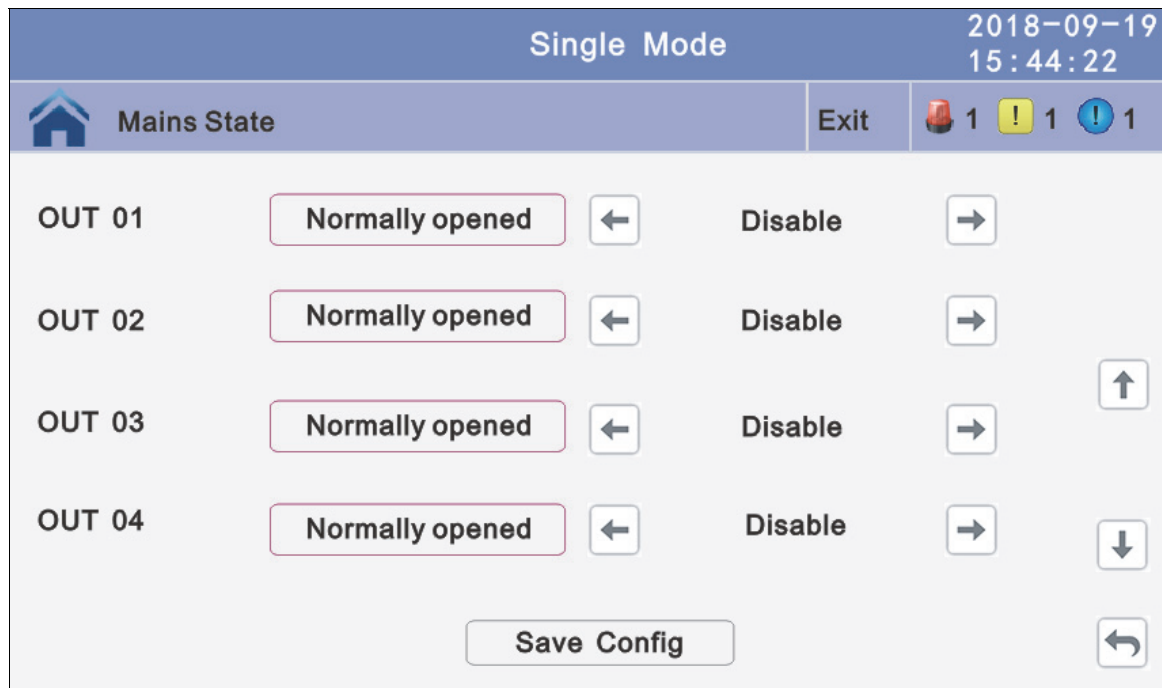

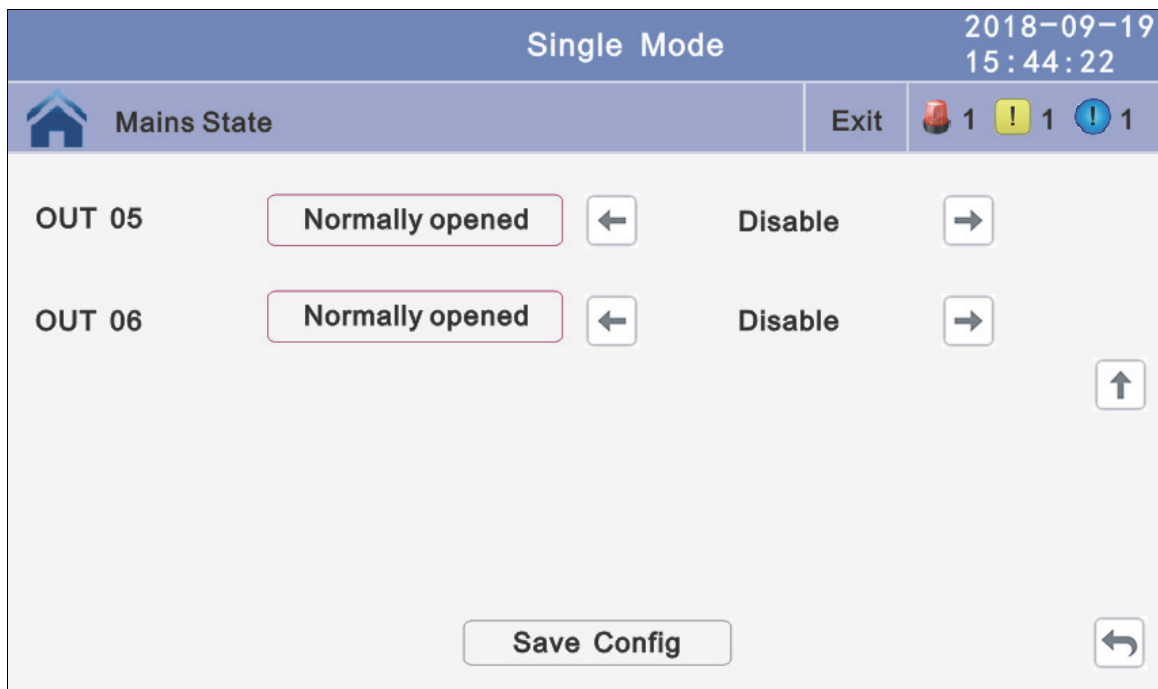

**4.3.5 Maint:** Software update, Touch correction, history download and battery self-test.

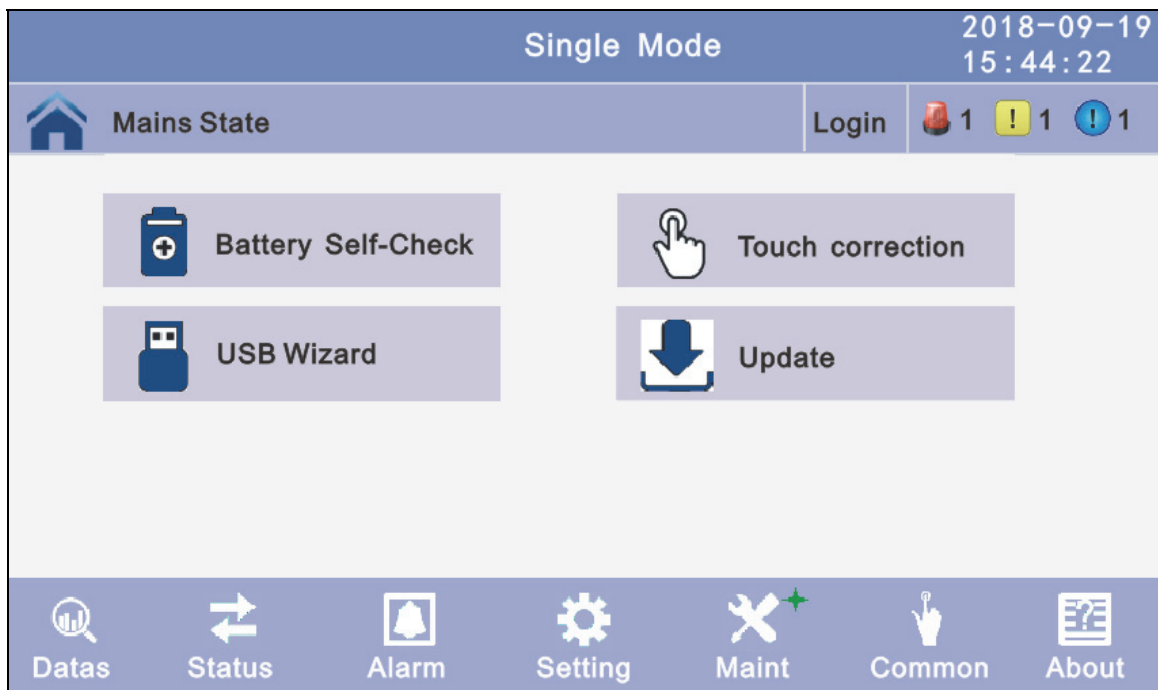

#### 4.3.5.1 USB Wizard: History Output, download history and setting record by USB

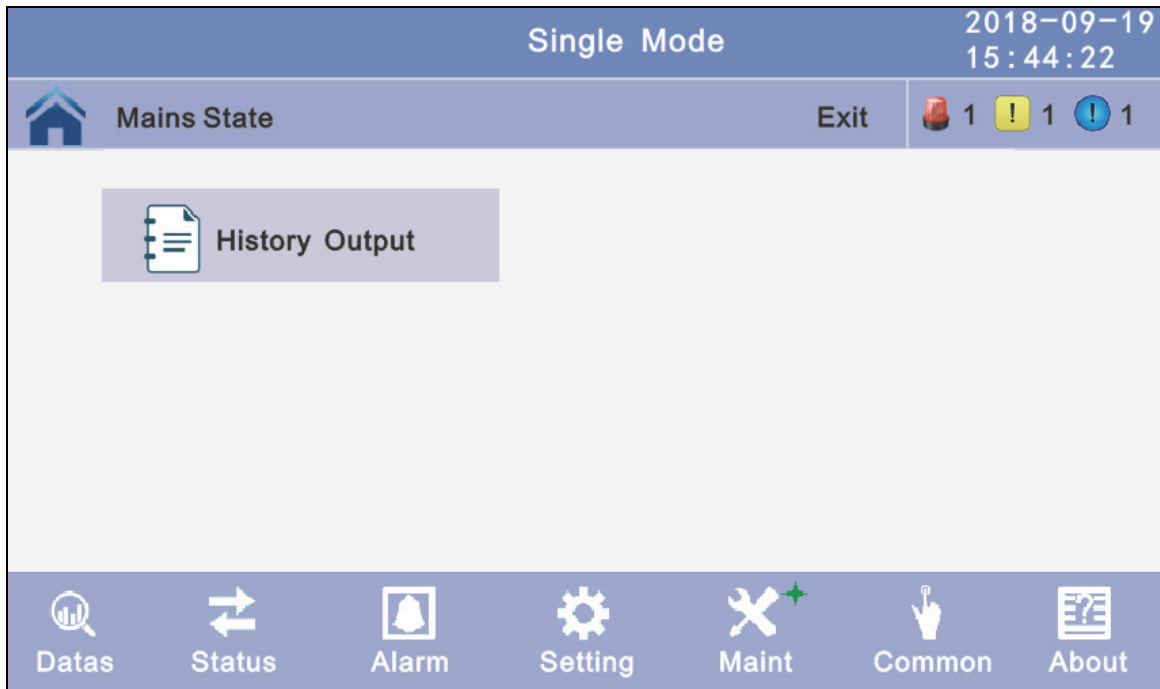

##### 4.3.5.1.1 Alarm Log Output

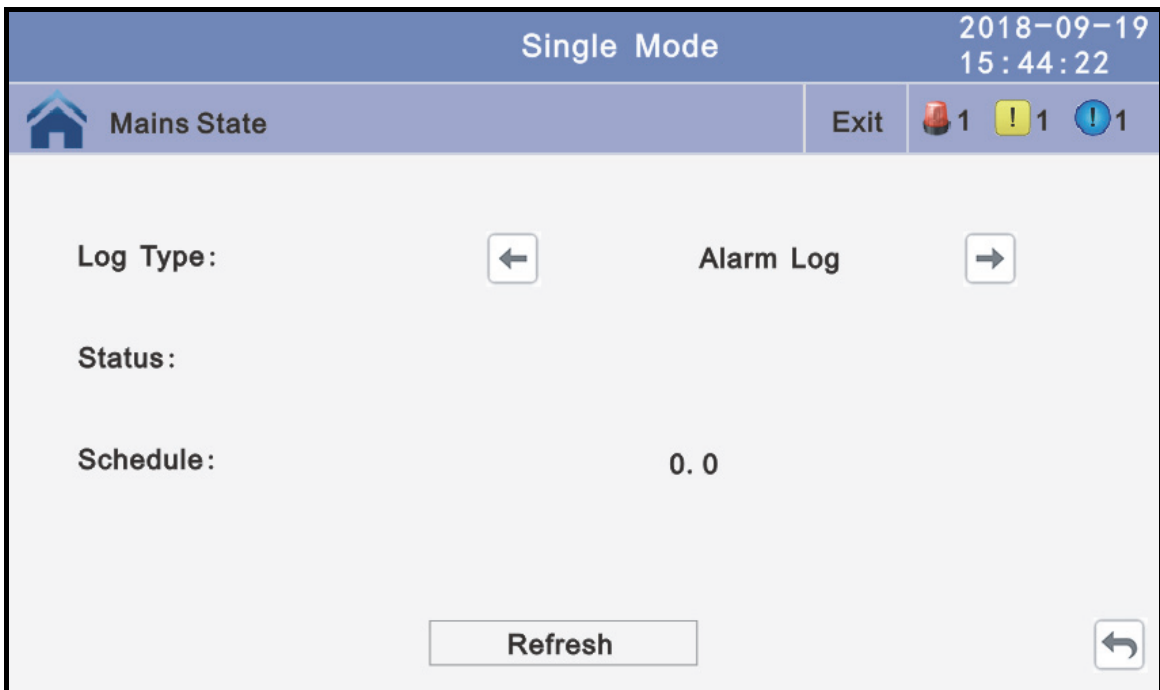

#### 4.3.5.1.2 Setting Log Output:

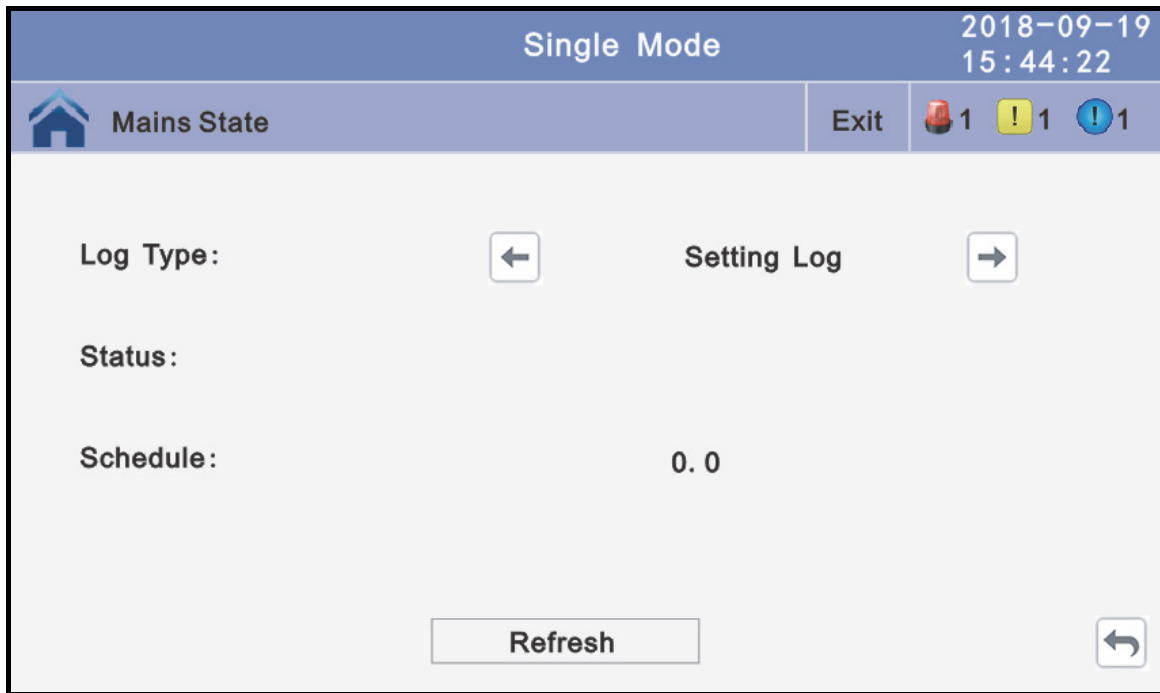

**4.3.5.2 Battery Self-Check:** can select check by Timing Daily, Timing Weekly, Cycle mode. The default value is Timing Self-Check Close.

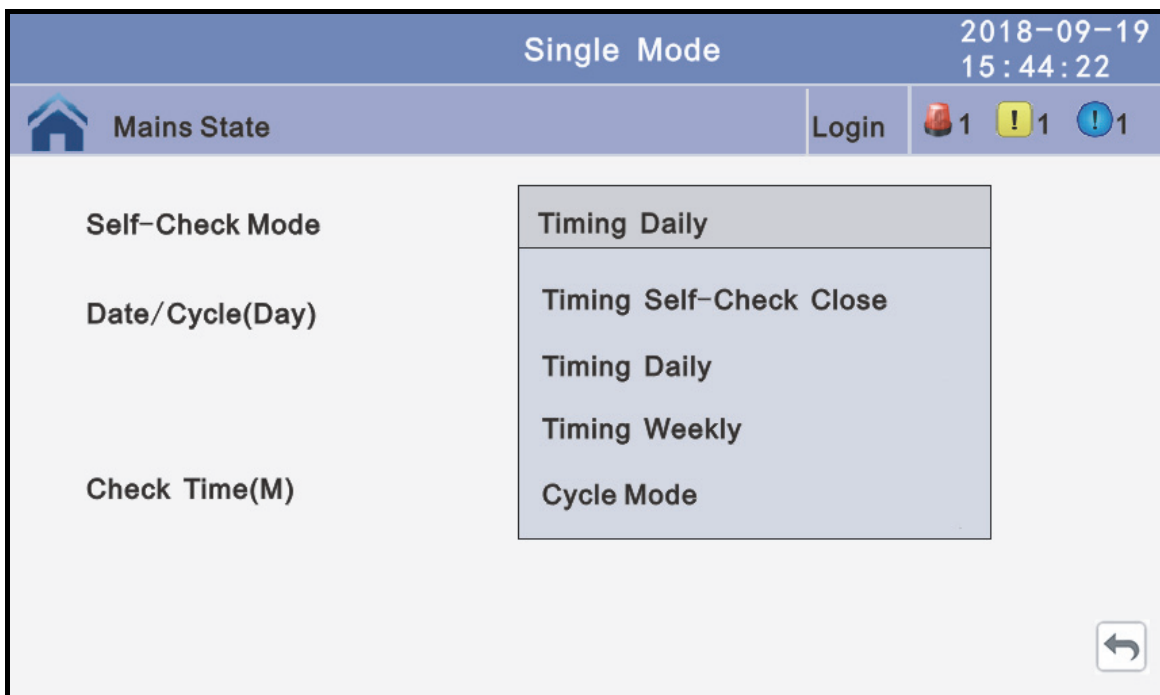

**4.3.5.2.1 Timing Daily:** modify the check date, time and check time (10S (default), 10min, EOD).

The screenshot shows the 'Timing Daily' configuration screen. At the top, it says 'Single Mode' and the date/time is '2018-09-19 15:44:22'. Below that, there's a 'Mains State' section with a 'Login' button and three notification icons (red, yellow, blue) each with a '1'. The 'Self-Check Mode' is set to 'Timing Daily'. The 'Date/Cycle(Day)' is set to '20 Day', '20 Hour', and '20 Min'. The 'Check Time(M)' is set to '10s' with left and right arrow buttons. At the bottom, there is a 'Save Config' button and a back arrow.

**4.3.5.2.2 Timing Weekly:** modify the check date, time and check time (10S (default), 10min, EOD).

The screenshot shows the 'Timing Weekly' configuration screen. At the top, it says 'Single Mode' and the date/time is '2018-09-19 15:44:22'. Below that, there's a 'Mains State' section with a 'Login' button and three notification icons (red, yellow, blue) each with a '1'. The 'Self-Check Mode' is set to 'Timing Weekly'. The 'Date/Cycle(Day)' is set to 'Monday' with left and right arrow buttons. The 'Check Time(M)' is set to '10s' with left and right arrow buttons, and a '10s' button is highlighted. At the bottom, there is a 'Save Config' button and a back arrow.

**4.3.5.2.3 Timing Cycle mode:** modify the cycle date and check time (10S (default), 10min, EOD).

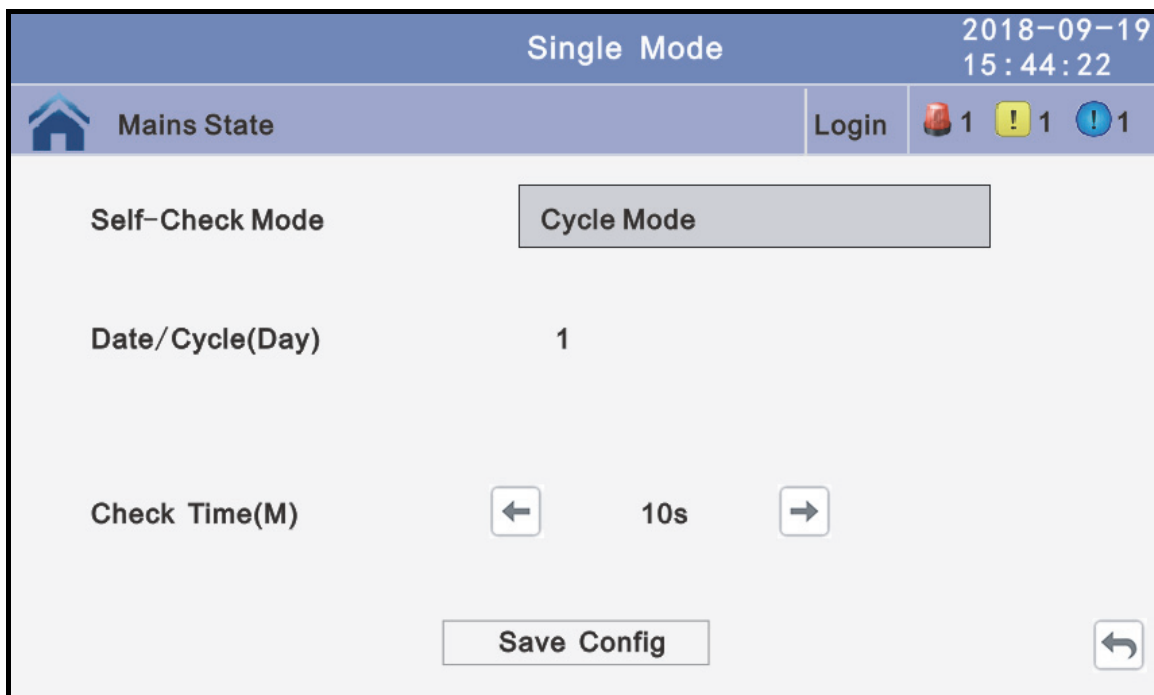

**4.3.6 Common:** INV ON/OFF, Battery test and Fault clear.

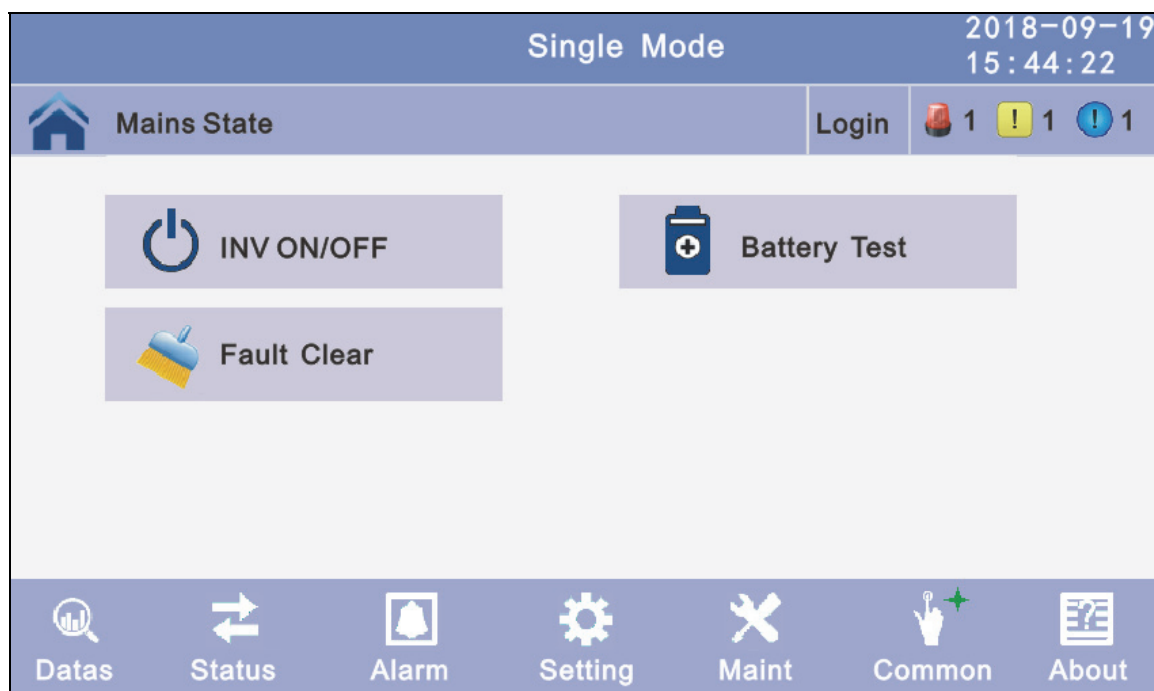

#### 4.3.6.1 INV ON/OFF

**Single OFF:** Inverter OFF location UPS

**Single ON:** Inverter ON location UPS

**Parallel OFF:** Inverter OFF all parallel UPSs

**Parallel ON:** Inverter ON all parallel UPSs

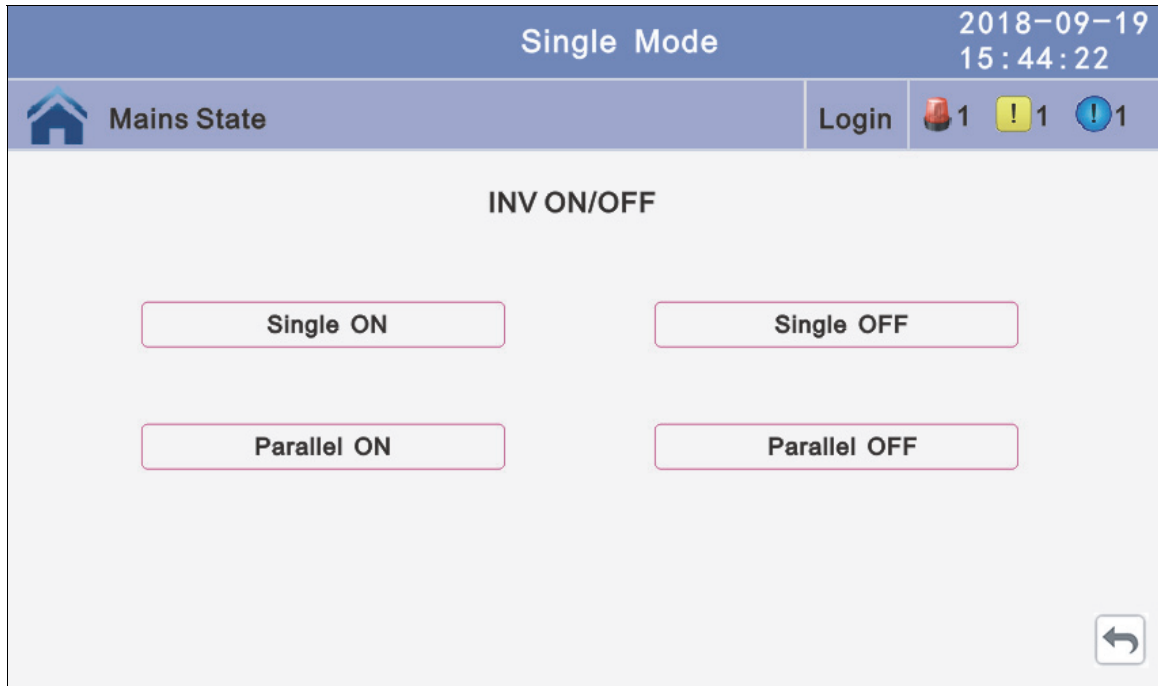

#### 4.3.6.2 Battery Test

**10S:** battery test for 10s

**10min:** battery test for 10min

**EOD:** battery test to EOD

**-10%:** battery test down 10% capability.

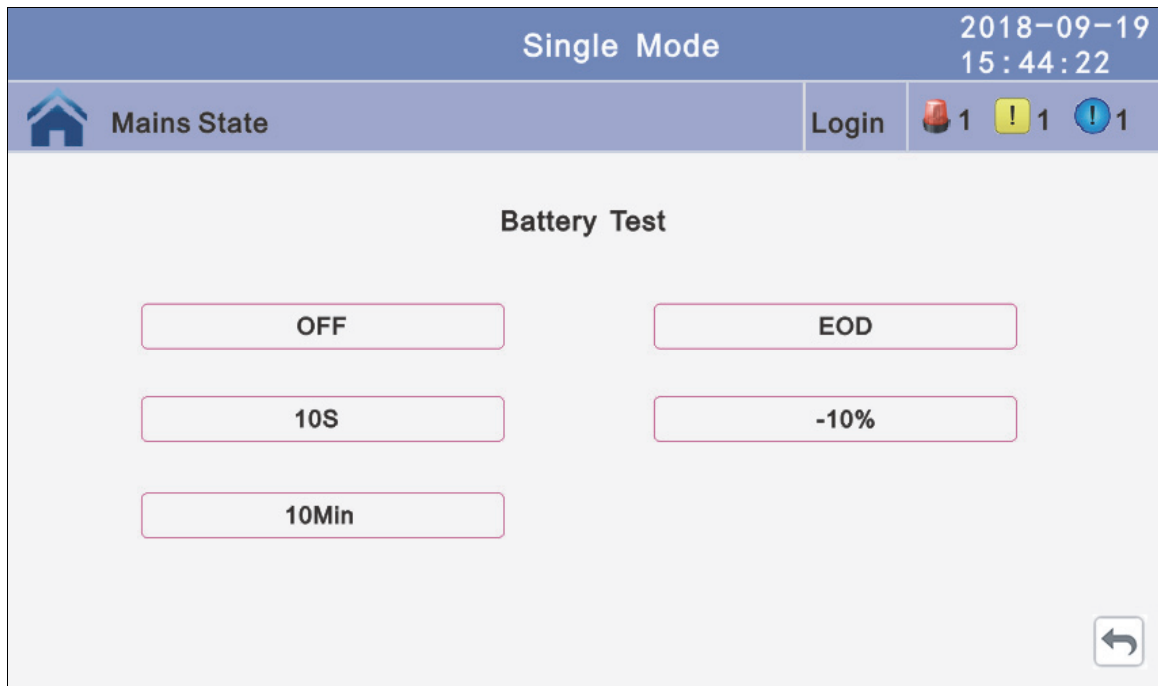

**4.3.6.3 Fault clear:** Clear the current fault (not for all faults).

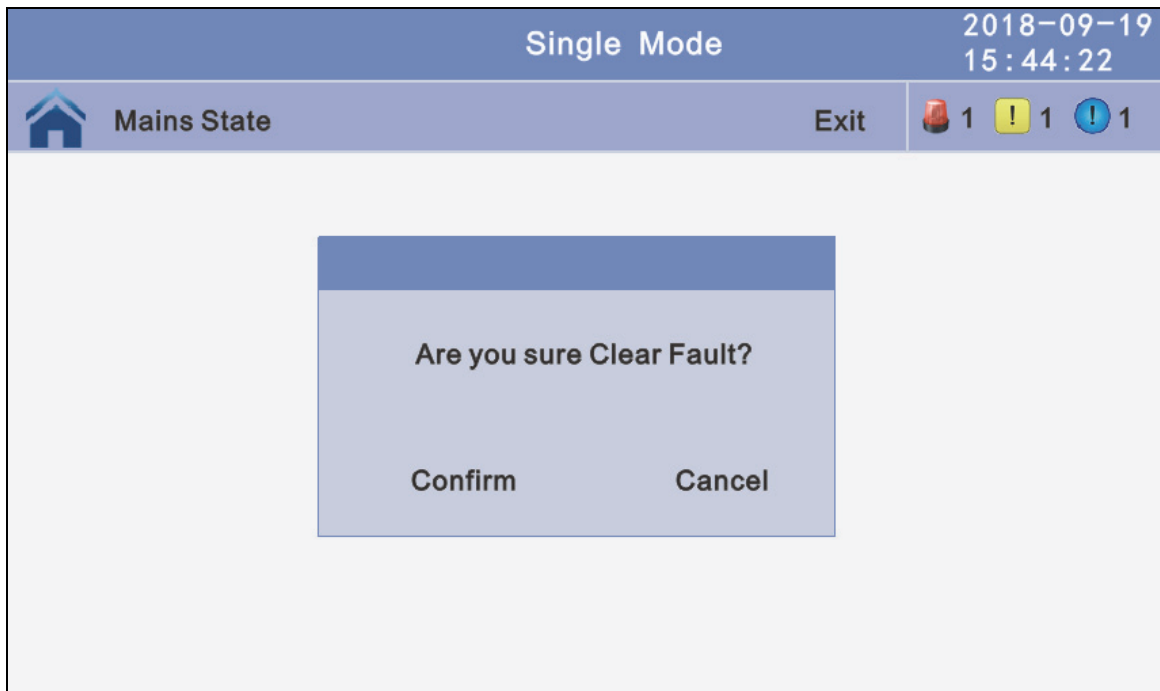

#### 4.3.7 About: check the software version

##### 4.3.7.1 Monitor and LCD software version

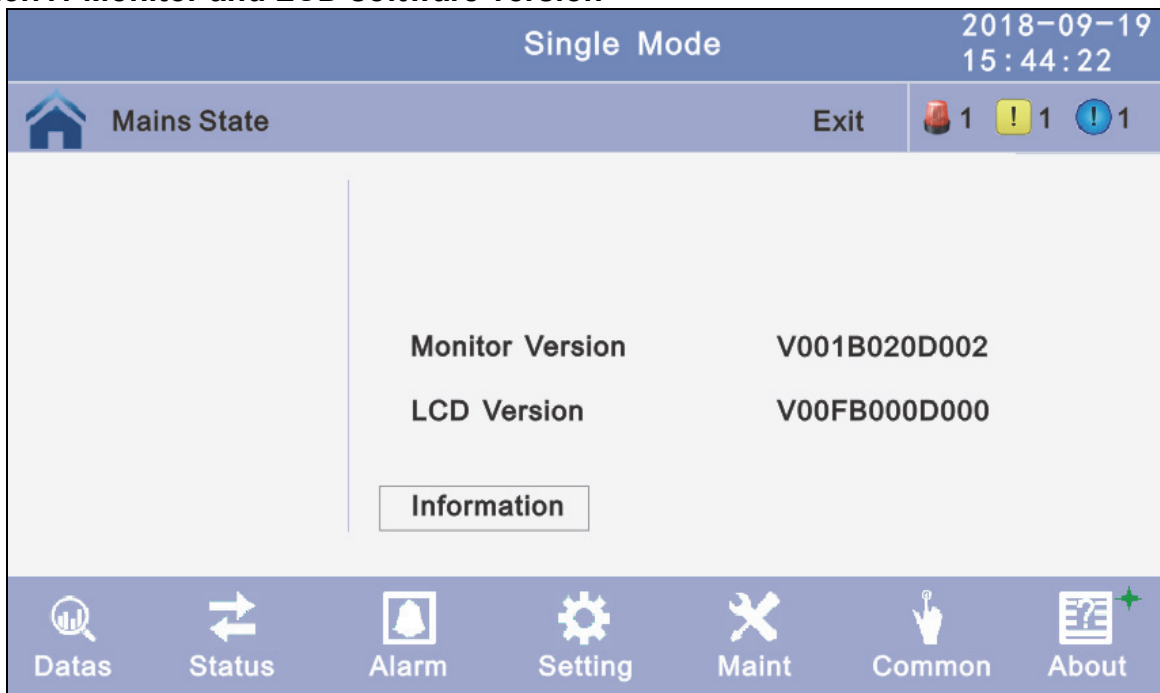

#### 4.4 Display Messages/Troubleshooting

This section lists the event and alarm messages that the UPS might display. The messages are listed in alphabetical order. This section is listed with each alarm message to help you troubleshoot problems.

##### Fault Information

No	Fault Cord	UPS Alarm Warning	Buzzer	LED
1	2	REC Over Temperature	Twice per second	Fault LED lit
2	3	REC par. cable Fault	Twice per second	Fault LED lit
3	4	REC Over Current	Beep continuously	Fault LED lit

No	Fault Cord	UPS Alarm Warning	Buzzer	LED
4	5	REC Power Fault	Beep continuously	Fault LED lit
5	7	Input SCR Fault	Beep continuously	Fault LED lit
6	10	Battery SCR Fault	Beep continuously	Fault LED lit
7	12	Charge SCR Fault	Beep continuously	Fault LED lit
8	14	Fan Fault	Beep continuously	Fault LED lit
9	17	Fan Power fault	Beep continuously	Fault LED lit
10	18	Charger Over Temp.	Beep continuously	Fault LED lit
11	19	Soft Start Failed	Beep continuously	Fault LED lit
12	20	BAT Charger Fault	Beep continuously	Fault LED lit
13	22	REC Comm. Fault	Once per 2 seconds	Fault LED blinking
14	25	REC Initializes Fault	Beep continuously	Fault LED lit
15	29	Unit insert fault	Once per 2 seconds	Fault LED lit
16	99		Once per 2 seconds	Fault LED lit
17	30	Rectifier Fault	Beep continuously	Fault LED lit
18	65	Inverter Fault	Beep continuously	Fault LED lit
19	68	INV IGBT SHORT	Beep continuously	Fault LED lit
20	71	Inverter relay Short	Beep continuously	Fault LED lit
21	74	Inverter relay Broken	Beep continuously	Fault LED lit
22	77	INV par. cable Fault	Twice per second	Fault LED lit
23	81	Output Short Circuit	Once per second	Fault LED blinking
24	84	INV Comm. Fault	Once per 2 seconds	Fault LED blinking
25	87	INV Initializes Fault	Beep continuously	Fault LED lit
26	90	INV self-test Fault	Beep continuously	Fault LED lit
27	94	DC Component Fault	Once per 2 seconds	Fault LED lit
28	97	DC bus abnormal	Beep continuously	Fault LED lit
29	100	INV DSP Power Fault	Beep continuously	Fault LED lit
30	102	INV Over Temperature	Twice per second	Fault LED lit
31	104	Load Sharing Fault	Twice per second	Fault LED lit
32	106	Cabinet mode Fault	Beep continuously	Fault LED lit
33	107	Fuse Broken	Beep continuously	Fault LED lit
34	129	Par. cable Fault	Twice per second	Fault LED lit
35	134	ECU Insert Fault	Once per 2 seconds	Fault LED lit
36	136	ECU Power Fault	Beep continuously	Fault LED lit
37	139	ECU Comm. Fault	Beep continuously	Fault LED lit
38	141	ECU Initializes Fault	Once per 2 seconds	Fault LED blinking
39	145	Bypass SCR Broken	Beep continuously	Fault LED lit
40	194		Beep continuously	Fault LED lit
41	148	Bypass SCR short	Beep continuously	Fault LED lit
42	197		Beep continuously	Fault LED lit
43	151	BPS Over Temperature	Beep continuously	Fault LED lit
44	207		Beep continuously	Fault LED lit

No	Fault Cord	UPS Alarm Warning	Buzzer	LED
45	154	Output CT Reverse	Beep continuously	Fault LED lit
46	155	Dry-contact Power Fault	Beep continuously	Fault LED lit
47	156	Dry-contact Comm. Fault	Beep continuously	Fault LED lit
48	157	Bypass Feedback Fault	Beep continuously	Fault LED lit
49	193	BYS Par.cable Fault	Beep continuously	Fault LED lit
50	200	BPS Comm. Fault	Beep continuously	Fault LED lit
51	202	Bypass Initializes Fault	Beep continuously	Fault LED lit
52	205	Bypass connected fault	Beep continuously	Fault LED lit
53	210	Bypass Fan Fault	Beep continuously	Fault LED lit

## Alarm Information

No	Alarm Cord	UPS Alarm Warning	Buzzer	LED
1	259	Battery Over Voltage	Once per second	Alarm LED lit
2	260	BAT Low Pre-warning	Once per second	Alarm LED lit
3	261	Battery Reverse	Twice per second	Alarm LED lit
4	262	Battery EOD	Once per second	Alarm LED lit
5	263	Battery Voltage low	Once per second	Alarm LED lit
6	264	No Battery	Once per second	Alarm LED lit
7	265	Input Phase Reverse	Once per second	Alarm LED lit
8	266	Input N-Line lost	Twice per second	Alarm LED lit
9	267	Mains Freq. Abnormal	Once per 2 seconds	Alarm LED lit
10	268	Mains Volt. Abnormal	Once per 2 seconds	Alarm LED lit
11	269	REC Comm. Error	Once per 2 seconds	Alarm LED lit
12	270	Mains input lost	Once per 2 seconds	Alarm LED lit
13	271	Set Data Err.	Once per 2 seconds	Alarm LED lit
14	289	INV Par. cable abnormal	Once per 2 seconds	Alarm LED lit
15	293	INV Overload	Once per 2 seconds	Alarm LED lit
16	294	INV not synchronized	Beep continuously	Alarm LED lit
17	298	INV Set Data Err	Once per 2 seconds	Alarm LED lit
18	297	INV Comm. Error	Once per 2 seconds	Alarm LED lit
19	321	Bypass Switch to Num	Once per 2 seconds	Alarm LED lit
20	322	Unit quantity mismatch	Once per 2 seconds	Alarm LED lit
21	323	Parallel Overload	Once per 2 seconds	Alarm LED lit
22	324	Bypass Overload	Once per 2 seconds	Alarm LED lit
23	325	Maint. Switch Misuse	Once per 2 seconds	Alarm LED lit
24	326	ECU Comm. Error	Once per 2 seconds	Alarm LED lit
25	327	Par. cable abnormal	Once per 2 seconds	Alarm LED lit
26	331	ECU Par. cable abnormal	Once per 2 seconds	Alarm LED lit
27	332	ECU Abnormal	Once per 2 seconds	Alarm LED lit
28	334	BPS Phase Reversed	Once per second	Alarm LED lit
29	354		Once per second	Alarm LED lit

No	Alarm Cord	UPS Alarm Warning	Buzzer	LED
30	335	BPS Unable To Trace	Once per 2 seconds	Alarm LED lit
31	355		Once per 2 seconds	Alarm LED lit
32	336	BPS Not Available	Once per second	Alarm LED lit
33	356		Once per second	Alarm LED lit
34	337	Ecu Set Data Err	Once per 2 seconds	Alarm LED lit
35	353	BPS Par.cable abnormal	Once per 2 seconds	Alarm LED lit
36	357	Bypass Comm. Error	Once per 2 seconds	Alarm LED lit
37	358	Bypass module take over	Once per 2 seconds	Alarm LED lit

## 4.5 Options

### Network Management Card with Environmental Monitoring



#### CAUTION!

For network management configuration and use, refer to the separate user manual - Network Management Card with Environmental Monitor - shipped with the CARD.

#### *Network Management Card replacement*

SNMP card: internal SNMP / external SNMP optional

- ◆ Loosen the 2 torque screws (on each side of the card).
- ◆ Carefully pull out the card. Reverse the procedure for re-installation

The slot called SNMP supports the MEGAtec protocol. We advise that NetAgent II-3 port is also a tool to remotely monitor and manage any UPS system

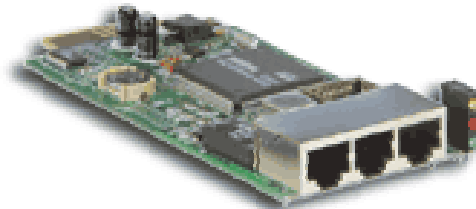

The overview of the SNMP card

NetAgent II-3Ports supports the Modem Dial-in (PPP) function to enable the remote control via the internet when the network is unavailable.

In addition to the features of a standard NetAgent Mini, NetAgent II has the option to add NetFeeler Lite to detect temperature, humidity, smoke and security sensors. Thus, making NetAgent II a versatile management tool. NetAgent II also supports multiple languages and is setup for web-based auto language detection.

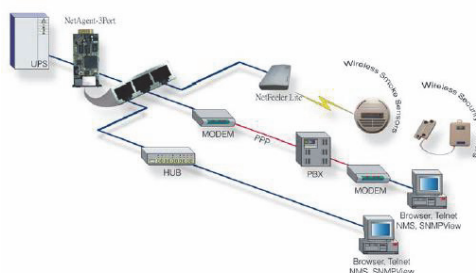

Typical topology of the UPS Network Management

## Appendix 1 Specifications

Model		300kVA	400kVA	500kVA	600kVA	
Cabinet capacity (VA/W)		300k / 300k	400k / 400k	500k / 500k	600k / 600k	
Input	Phase	3 Phase 4 Wires and Ground				
	Rated Voltage	380/400/415Vac				
	Voltage Range	138~485Vac ◆ At 40°C: The UPS works at full load when the voltage is 323~485Vac and is derated load when the voltage is 323~138Vac ◆ At 30°C: The UPS works at full load when the voltage is 305~485Vac and is derated load when the voltage is 305~138Vac				
	Frequency Range	40Hz-70Hz				
	Power Factor	≥0.99				
	Current THDi	≤3%(100% nonlinear load)				
	Bypass Voltage Range	Max.voltage: 220V:+25 %( optional +10%, +15%, +20%); 230V:+20 %( optional +10%, +15%); 240V:+15 %( optional +10%); Min. voltage:-45 %( optional -10%, -20%,-30%) Frequency protection range: ±10%				
	Output	Phase	3 Phase 4 Wires and Ground			
Rated Voltage		380/400/415Vac				
Power Factor		1.0				
Voltage Regulation		±1%				
Frequency		Utility Mode	±1%/±2%/±4%/±5%/±10%of the rated frequency(optional)			
		Battery Mode	(50/60±0.1)Hz			
Crest Factor		3:1				
THD		≤2% with linear load ≤4% with non linear load				
Overload	Inverter overload capability: ◆ 105% < load ≤ 110%: transfer to bypass mode after 60 min ◆ 110% < load ≤ 125%: transfer to bypass mode after 10 min ◆ 125% < load ≤ 150%: transfer to bypass mode after 1 min Bypass overload capability: ◆ Temperature ≤ 30°C, load ≤ 135%: run for a long time ◆ Temperature ≤ 40°C, load ≤ 125%: run for a long time ◆ 1000% load: run for 100 ms					
Battery	Voltage	Optional Voltage: ±180V/192V/±204V/±216V/±228V/±240/±252/±264/±276/ ±288/±300Vdc(30/32/34/36/38/40/42/44/46/48/50pcs optional) 360Vdc~600Vdc (30~50 pcs, 30 pcs define, 32 and 50 pcs no power derating; 30 pcs output power factor 0.8 ; )				
	Charge current (A) max.	100A	140A	180A	200A	

<b>Transfer Time</b>		Utility to Battery : 0ms; Utility to bypass: 0ms		
<b>Protection</b>	Short Circuit	Hold Whole System		
	Overheat	Line Mode: Switch to Bypass; Backup Mode: Shut down UPS immediately		
	Battery Low	Alarm and Switch off		
	Self-diagnostics	Upon Power On and Software Control		
	EPO	Shut down UPS immediately		
	Battery	Advanced Battery Management		
	Noise Suppression	Complies with EN62040-2		
<b>Communication Interface</b>		RS232, RS485, LBS, Parallel, Relay card, SNMP card(optional)		
<b>Environment</b>	Operating Temperature	0°C ~ 40°C		
	Storage Temperature	-25°C ~ 55°C		
	Humidity	0 ~ 95% non condensing		
	Altitude	< 1500m		
<b>Display</b>	Audible & Visual	Line Failure, Battery Low, Overload, System Fault		
	Status LED	UPS Fault, Alarm and normal		
	Reading On the LCD	Input Voltage, Input Frequency, Output Voltage, Output Frequency, Load Percentage, Battery Voltage, parameter set, history record...		
<b>Other</b>	Standard cabinet Dimensions(W*D*H)			
	Full cabinet Dimensions(W*D*H) (mm)	600*850*1600	600*850*2000	1200*850*2000
<b>Safety Conformance</b>		CE, EN/IEC 62040-3, EN/IEC 62040-1-1		

## Appendix 2 Problems and Solution

In case the UPS cannot work normally, it might be wrong in installation, wiring or operation. Please check these aspects first. If all these aspects are checked without any problem, please consult with local agent right away and provide below information.

- ( 1 ) Product model name and serial number, which can be found in LCD display.
- ( 2 ) Try to describe the fault with more details, such as LCD display info, LED lights status, etc.

Read the user manual carefully, it can help a lot for using this UPS in the right way. Some FAQ (frequently asked questions) may help you to troubleshoot your problem easily.

No.	Problem	Possible reason	Solution
1	LCD not display	The network cable is not fixed properly or the telephone line of the front door is not fixed properly.	Connect the network cable and telephone cable properly.
2	LCD Blue screen	LCD is Interference	Take out the cable and insert back properly
3	Utility is connected but the UPS cannot be powered ON.	Input power supply is not connected; Input voltage low;	Measure if the UPS input voltage/frequency is within the window.
4	Utility normal but Utility LED does not light on, and the UPS operates at battery mode	input cable is not well connected	Switch on the input switch; Make sure the input cable is well connected.
5	The UPS does not indicate any failure, but output do not have voltage	Output cable does not well connected	Make sure the output cable is well connected.
6	The UPS cannot transfer to bypass or inverter	Output switch do not switch on	Switch on the output switch.
7	Utility LED is flashing	Utility voltage exceeds UPS input range.	If the UPS operates at battery mode, please pay attention to the remaining backup time needed for your system.
8	Battery LED is flashing but no charge voltage and current	Battery switch does not switch on, or batteries are damaged, or battery is reversely connected. Battery number and capacity are not set correctly.	Switch on the battery switch. If batteries are damaged, need to replace whole group batteries, Connect the battery cables correctly; Go to LCD setting of the battery number and capacity, set the correct data.
10	Buzzer beeps every 0.5 seconds and LCD display "output overload"	Overload	remove some load
11	Buzzer long beeps, LCD display "output short circuit"	The UPS output is in short circuit	Make sure the load is not in short circuit, and then restart the UPS.
12	The UPS only works on bypass mode	The UPS is set to ECO mode, or the transfer times to bypass mode are limited.	Set the UPS working mode to Single type(non-parallel) or to reset the times of transferring to bypass or re-start the UPS

13	Cannot Black start	Battery switch is not properly closed; Battery fuse is not open; Or Battery low	Close the battery switch; Change the fuse; Recharge the battery
14	Buzzer beeps continuously and LCD indicates Rectifier fault or output fault	UPS is out of order	Consult with your local agent for repair

### Appendix 3 CAN communication port definition

Definition of port:

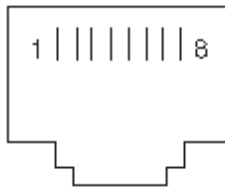

Connection between the Device's CAN converter port and UPS CAN port.

BMS	UPS (RJ45)	Description
PIN 1	PIN 1	CAN_H
PIN 2	PIN 2	CAN_L
PIN 3/7	PIN 3/7	CAN_GND

Available function of CAN

- ◆ Communicate to BMS.
- ◆ Communicate to remote LCD.

## Appendix 4 RS485 communication port definition

Definition of port:

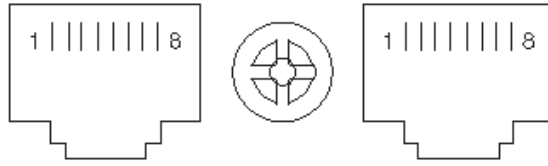

Connection between the Device's RS485 port and UPS RS485 port.

device(RJ45)	UPS(RJ45)	Description
Pin 1/5	Pin 1/5	485+ "A"
Pin 2/4	Pin 2/4	485 - "B"

Available function of RS485

- ◆ Monitor UPS power status.
- ◆ Monitor UPS alarm info.
- ◆ Monitor UPS running parameters.
- ◆ Timing off /on setting.

RS485 communication data format

Baud rate ----- 9600bps

Byte length ----- 8bit

End bit ----- 1bit

Parity check -----none

## Appendix 5 BAT\_T communication port definition

Definition of port:

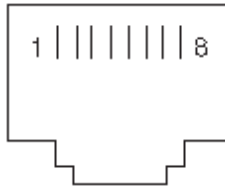

Connection between the battery temperature sensor's RS485 port and UPS BAT\_T port.

device(RJ45)	UPS(RJ45)	Description
Pin 1/5	Pin 1/5	485+ "A"
Pin 2/4	Pin 2/4	485 - "B"

Available function of RS485

- ◆ communicate to battery temperature sensor

RS485 communication data format

Baud rate ----- 9600bps

Byte length ----- 8bit

End bit ----- 1bit

Parity check -----none

## Appendix 6 LBS port definition

Definition of port:

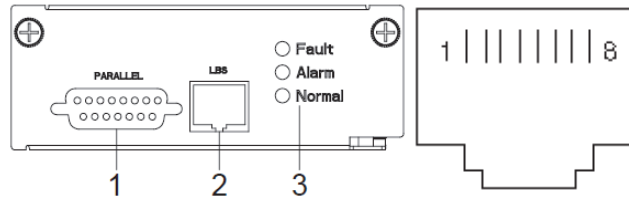

Connection between the UPS LBS port.

UPS(RJ45)	UPS(RJ45)	Description
Pin 1/2/3	Pin 1/2/3	LBS
Pin 5/7/8	Pin 5/7/8	GND

Available function of LBS

- ◆ The output power of two or more UPS in non-parallel system should be synchronized with each other.
- ◆ The output phase of two or more UPS in non-parallel system should be synchronized with each other.



### CAUTION!

Two or more LBS cables must be used to form a ring when two or more LBS in non-parallel system. And the cables must use horizontal line.

## Appendix 7 REPO instruction

Definition of port:

Connection diagram:

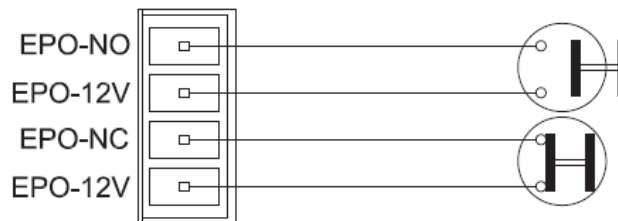

Connection between the button and UPS REPO port.

Button	UPS REPO	Description
Pin 1	Pin 1	EPO-NO
Pin 2	Pin 2	EPO-12V
Pin 1	Pin 3	EPO-NC
Pin 2	Pin 4	EPO-12V

- ◆ A remote emergency stop switch can be installed in a remote location and connection through simple wires to the REPO connector.